

THE STATE OF DELAWARE



DEPARTMENT OF TRANSPORTATION  
MAINTENANCE AND OPERATIONS  
CONSTRUCTION PLANS AND SPECIFICATIONS FOR

COMMUNITY TRANSPORTATION FUND, NEW CASTLE IX, 2026

CONTRACT NUMBER - T202603109

UNIFIER PROJECT ID – 2026-00067

FEDERAL AID NUMBER - NONE

COUNTY: NEW CASTLE

PLANS PREPARED BY:   
DESIGNER



2/5/2026

DELDOT – CANAL DISTRICT MAINTENANCE ENGINEER  
MAINTENANCE AND OPERATIONS - (CAD)

DATE

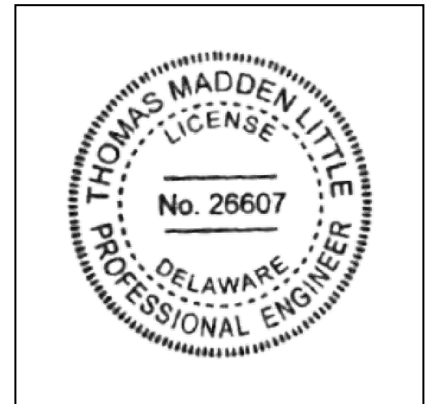

THIS SEAL APPLIES TO ALL SHEETS  
BEARING THE "CAD" SECTION  
DESIGNATION

APPROVED FOR ADVERTISEMENT

Type text here

*Pamela Steinobach*

2/6/26

DIRECTOR OF MAINTENANCE AND OPERATIONS

DATE

---

DEPARTMENT OF TRANSPORTATION

---

CONTRACT NUMBER- T202603109

(CAD) PAGE 2 OF 73

---

CONTRACT IS FOR VARIOUS LOCATIONS THROUGHOUT NEW CASTLE COUNTY.

---

LOCATION MAP

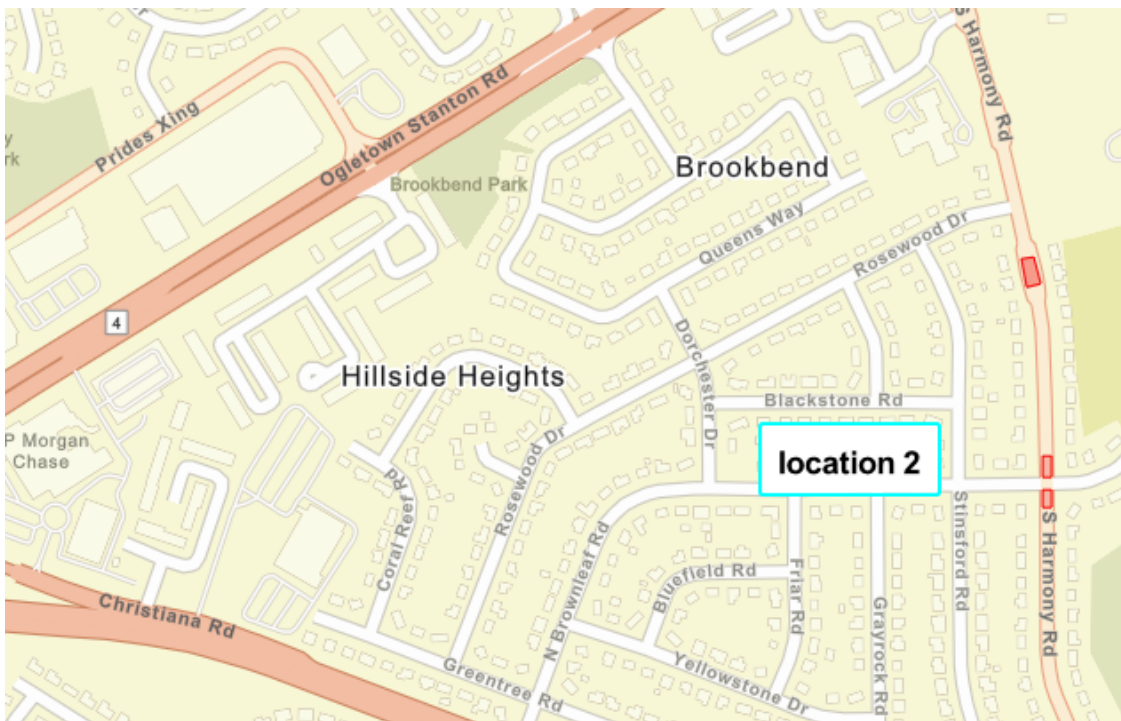

---

DEPARTMENT OF TRANSPORTATION

---

CONTRACT NUMBER- T202603109

(CAD) PAGE 3 OF 73

---

CONTRACT IS FOR VARIOUS LOCATIONS THROUGHOUT NEW CASTLE COUNTY.

---

LOCATION MAP



---

DEPARTMENT OF TRANSPORTATION

---

CONTRACT NUMBER- T202603109

(CAD) PAGE 4 OF 73

---

CONTRACT IS FOR VARIOUS LOCATIONS THROUGHOUT NEW CASTLE COUNTY.

---

LOCATION MAP

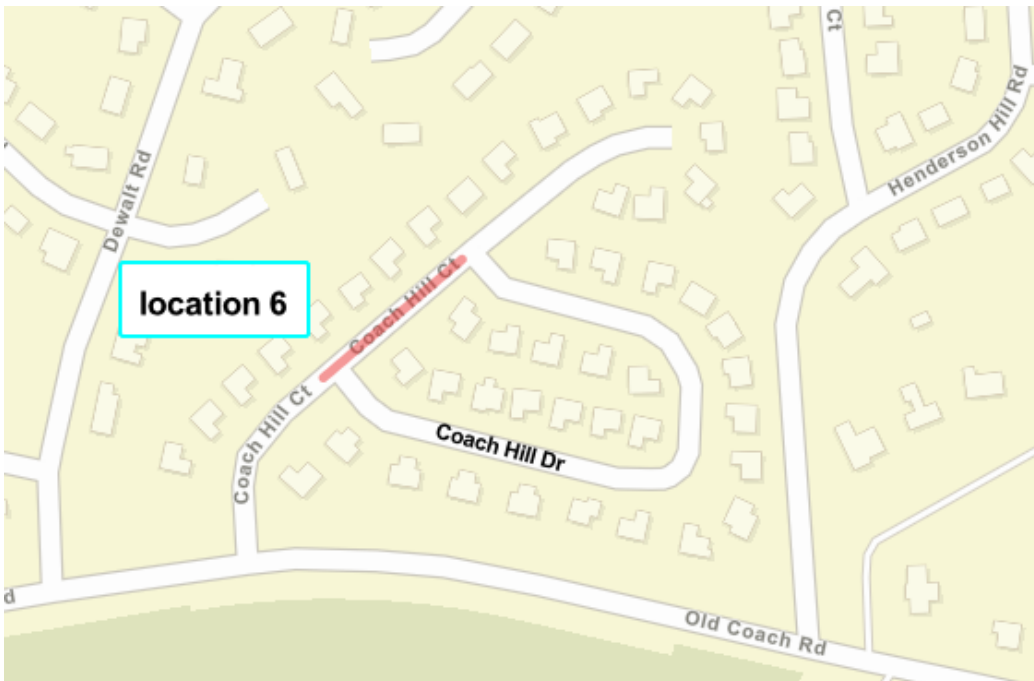

---

DEPARTMENT OF TRANSPORTATION

---

CONTRACT NUMBER- T202603109

(CAD) PAGE 5 OF 73

---

CONTRACT IS FOR VARIOUS LOCATIONS THROUGHOUT NEW CASTLE COUNTY.

---

LOCATION MAP

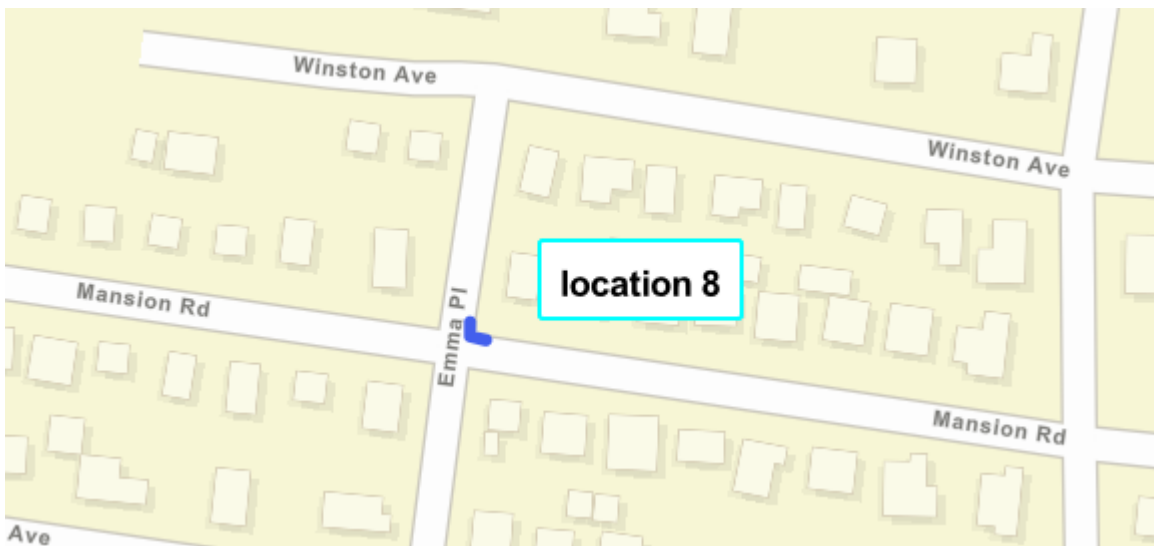

---

DEPARTMENT OF TRANSPORTATION

---

CONTRACT NUMBER- T202603109

(CAD) PAGE 6 OF 73

---

CONTRACT IS FOR VARIOUS LOCATIONS THROUGHOUT NEW CASTLE COUNTY.

---

LOCATION MAP



---

DEPARTMENT OF TRANSPORTATION

---

CONTRACT NUMBER- T202603109

(CAD) PAGE 7 OF 73

---

CONTRACT IS FOR VARIOUS LOCATIONS THROUGHOUT NEW CASTLE COUNTY.

---

LOCATION MAP



---

DEPARTMENT OF TRANSPORTATION

---

CONTRACT NUMBER- T202603109

(CAD) PAGE 8 OF 73

---

CONTRACT IS FOR VARIOUS LOCATIONS THROUGHOUT NEW CASTLE COUNTY.

---

LOCATION MAP



---

DEPARTMENT OF TRANSPORTATION

---

CONTRACT NUMBER- T202603109

(CAD) PAGE 9 OF 73

---

CONTRACT IS FOR VARIOUS LOCATIONS THROUGHOUT NEW CASTLE COUNTY.

---

LOCATION MAP

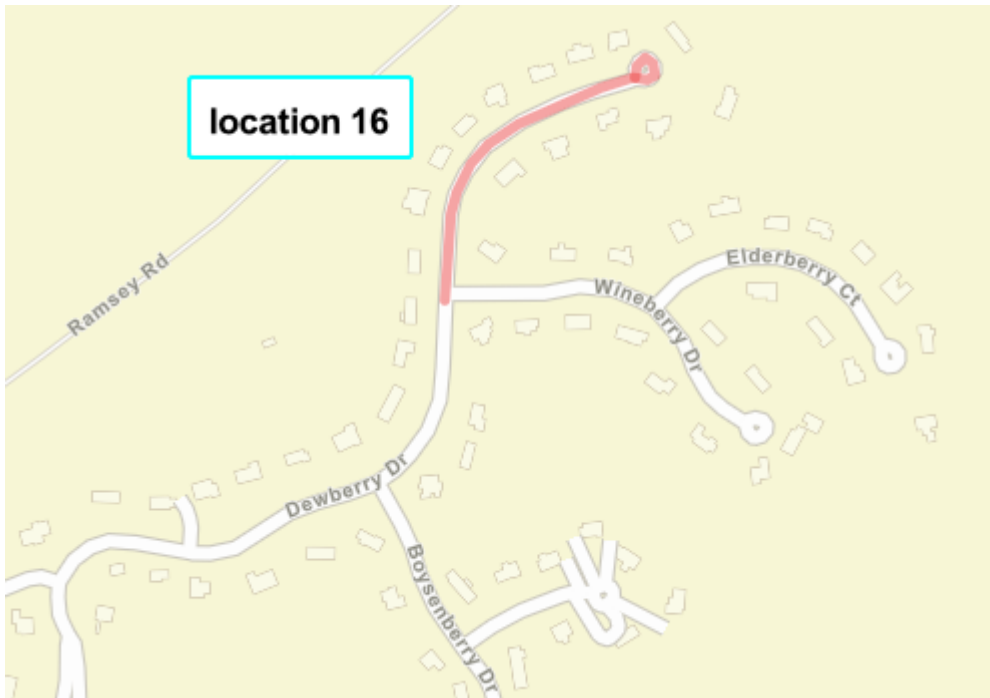

CONTRACT IS FOR VARIOUS LOCATIONS THROUGHOUT NEW CASTLE COUNTY.

LOCATION MAP

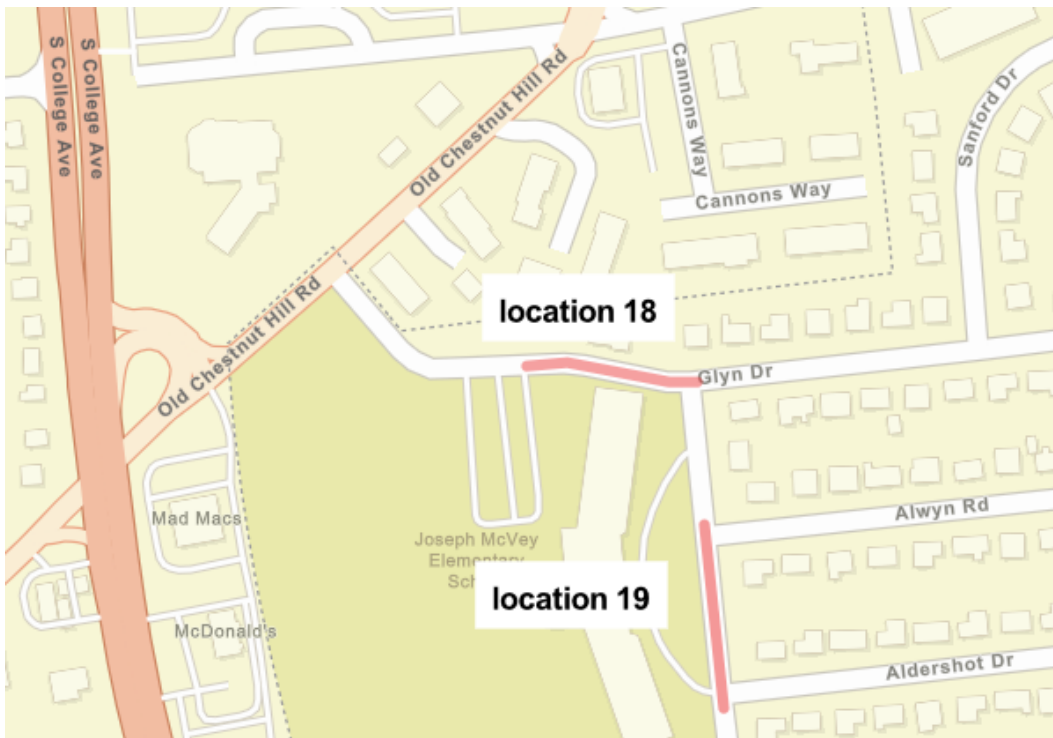

CONTRACT IS FOR VARIOUS LOCATIONS THROUGHOUT NEW CASTLE COUNTY.

LOCATION MAP



---

DEPARTMENT OF TRANSPORTATION

---

CONTRACT NUMBER- T202603109

(CAD) PAGE 12 OF 73

---

CONTRACT IS FOR VARIOUS LOCATIONS THROUGHOUT NEW CASTLE COUNTY.

---

LOCATION MAP



---

DEPARTMENT OF TRANSPORTATION

---

CONTRACT NUMBER- T202603109

(CAD) PAGE 13 OF 73

---

CONTRACT IS FOR VARIOUS LOCATIONS THROUGHOUT NEW CASTLE COUNTY.

---

LOCATION MAP

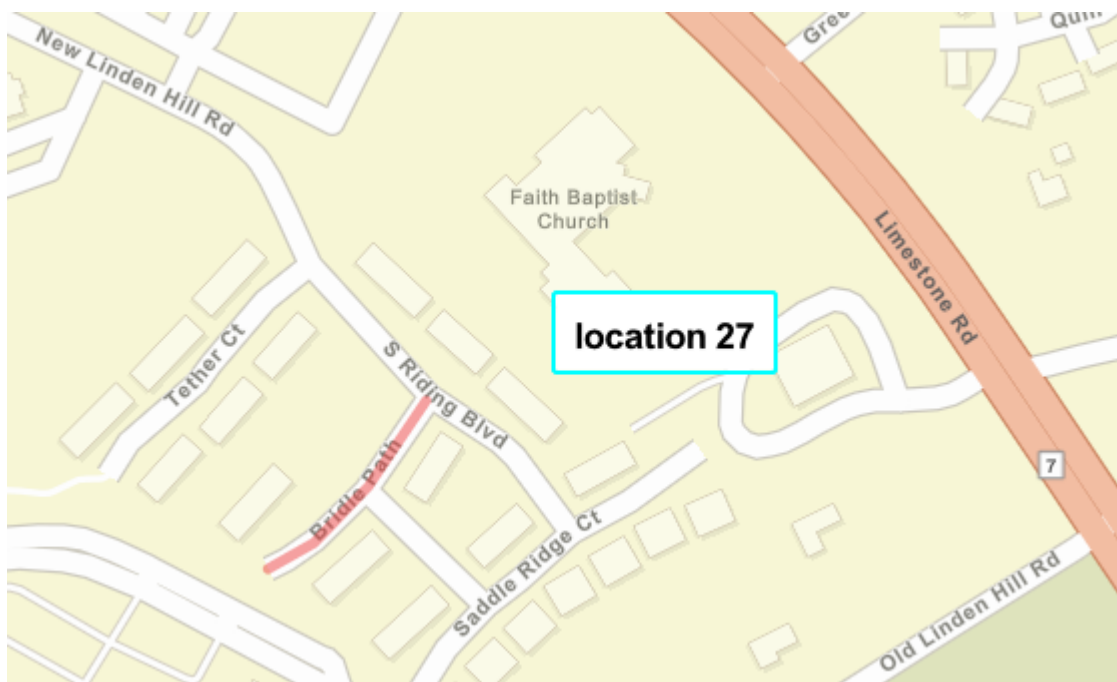
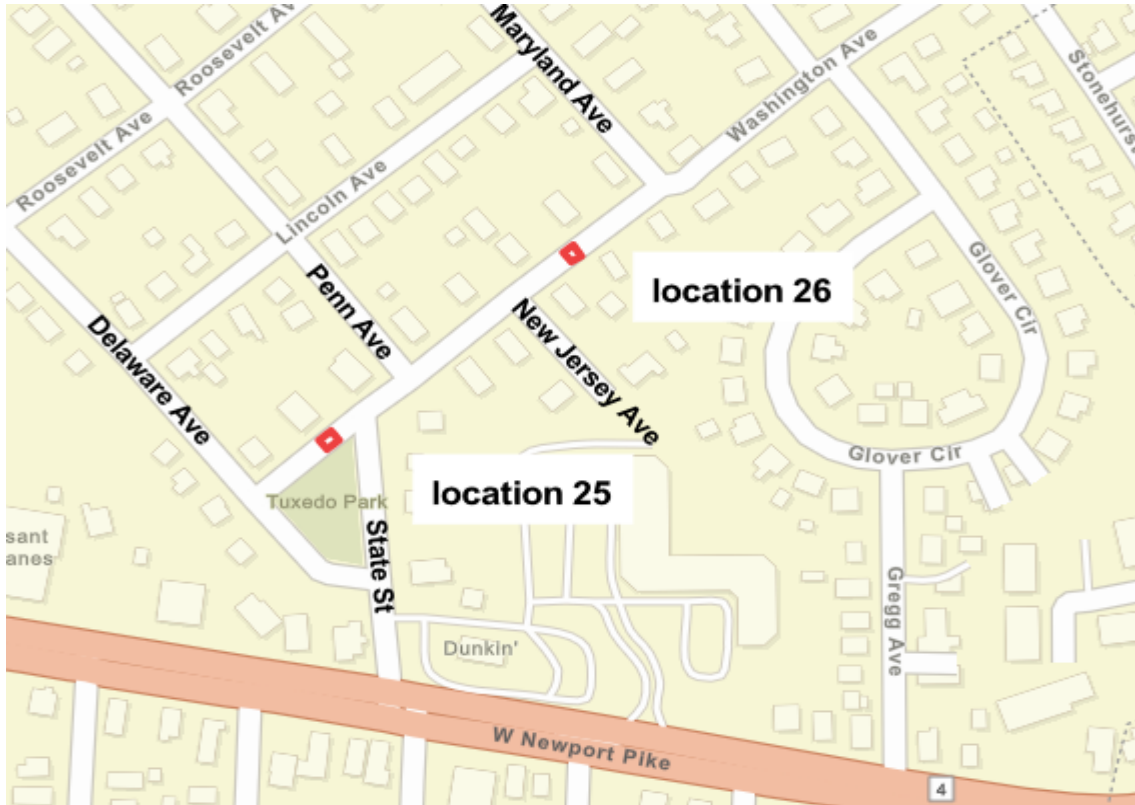

---

DEPARTMENT OF TRANSPORTATION

---

CONTRACT NUMBER- T202603109

(CAD) PAGE 14 OF 73

---

CONTRACT IS FOR VARIOUS LOCATIONS THROUGHOUT NEW CASTLE COUNTY.

---

LOCATION MAP



GENERAL CONTRACT PLAN NOTES

**SECTION 100**

1. THIS PROJECT IS TO BE CONSTRUCTED IN ACCORDANCE WITH THE DELAWARE DEPARTMENT OF TRANSPORTATION STANDARD SPECIFICATIONS FOR ROAD AND BRIDGE CONSTRUCTION DATED JANUARY 2025 AND THE DELAWARE DEPARTMENT OF TRANSPORTATION STANDARD CONSTRUCTION DETAILS DATED 2025, INCLUDING ALL REVISIONS UP TO THE DATE OF ADVERTISEMENT.

2. THE PURPOSE OF THIS CONTRACT IS TO MAKE GENERAL IMPROVEMENTS TO ROADS AND/OR STREETS WITHIN THE DISTRICT HEREIN SPECIFIED. DEPENDING ON FUND AVAILABILITY, THE DEPARTMENT RESERVES THE RIGHT TO ADD OR DELETE LOCATIONS AND/OR QUANTITIES FOR THIS CONTRACT. SUCH ADDITIONS OR DELETIONS SHALL NOT BE CAUSE FOR AN INCREASE OR DECREASE IN ANY CONTRACT UNIT BID PRICES. NO ITEM PRICES ARE TO BE RENEGOTIATED DUE TO EITHER AN INCREASE OR DECREASE IN QUANTITY USAGE RESULTING FROM SAID ADDITIONS OR DELETIONS.

3. THE CONTRACTOR SHALL PROVIDE WRITTEN NOTICE TO RESIDENTS AND BUSINESSES AT LEAST 48 HOURS, BUT NO MORE THAN 96 HOURS, PRIOR TO ALL PHASES OF CONTRACT WORK INCLUDING BUT NOT LIMITED TO: SAWCUTTING FOR P.C.C. OPERATIONS, P.C.C. REMOVAL AND REPLACEMENT, PAVEMENT MILLING, AND PAVING. THIS NOTICE SHALL BE GIVEN TO ALL RESIDENTS AND BUSINESSES WHOSE PROPERTY IS ADJACENT TO THE STREET ON WHICH WORK IS TO BE PERFORMED. FAILURE TO GIVE PROPER NOTICE WILL RESULT IN A SUSPENSION OF WORK REQUIRING NOTICE, UNTIL PROPER NOTICE IS PROVIDED. UPON COMPLETION OF DISTRIBUTING WRITTEN NOTICES, THE CONTRACTOR SHALL IMMEDIATELY NOTIFY THE ENGINEER.

4. LOCATION LISTINGS INDICATE GENERAL LIMITS OF CONSTRUCTION, MAJOR TYPES OF IMPROVEMENTS, AND ESTIMATED QUANTITIES. DURING THE BIDDING PERIOD, ANY QUESTIONS PERTAINING TO LOCATIONS SHALL BE DIRECTED TO THE CONTRACT ADMINISTRATOR. AFTER THE AWARD, SUCH QUESTIONS SHALL BE REFERRED TO THE APPROPRIATE DISTRICT ENGINEER OR HIS REPRESENTATIVE.

5. THIS CONTRACT WILL HAVE CLEAR "START BY" DATE AND TIME ALLOCATED FOR COMPLETION. FAILURE TO COMPLETE THE CONTRACT IN THE SPECIFIED TIME SHALL CONSTITUTE "FAILURE TO PURSUE THE WORK" AND SUBJECTS THE CONTRACTOR TO LIQUIDATED DAMAGES AS OUTLINED IN SUBSECTION 108.8 OF THE STANDARD SPECIFICATIONS.

6. THE CONTRACTOR SHALL SUBMIT THE REQUIRED COPIES OF A DETAILED PROGRESS SCHEDULE (PSC) AS OUTLINED IN STANDARD SPECIFICATION 108.4 PRIOR TO THE PRECONSTRUCTION MEETING. DETAILS SHALL INCLUDE A DESCRIPTION OF EACH WORK ACTIVITY, THE PLANNED DAYS OF WORK, MULTIPLE CREWS OR SHIFTS, AND SCHEDULED WORKING HOURS. DURING THE CONTRACT, THE CONTRACTOR SHALL SUBMIT TWO-WEEK (OR AS REQUIRED) "LOOK AHEAD" SCHEDULES TO THE AREA ENGINEER/ MANAGER NO LATER THAN

---

**DEPARTMENT OF TRANSPORTATION**

---

**CONTRACT NUMBER- T202603109 CANAL  
COMMUNITY TRANSPORTATION FUND, NEW CASTLE IX, 2026**

**(CAD) PAGE 16 OF 73**

---

**GENERAL CONTRACT PLAN NOTES**

NOON OF EACH THURSDAY. FAILURE TO COMPLY WILL RESULT IN A SUSPENSION OF ALL CONTRACT WORK WITH TIME CHARGES CONTINUING TO BE ASSESSED.

**ADDITIONAL WORK:**

7. THE DEPARTMENT RESERVES THE RIGHT TO INCREASE OR DECREASE THE QUANTITIES OF THE ITEMS SPECIFIED IN THIS CONTRACT. SUCH ADDITIONS SHALL NOT BE CAUSE FOR AN INCREASE OR DECREASE IN ANY CONTRACT UNIT BID PRICES AND/OR LUMP SUM ITEMS IF THE INCREASE IN QUANTITIES DOES NOT REQUIRE REMOBILIZATION.

8. THE DEPARTMENT RESERVES THE RIGHT TO ADD LOCATIONS TO THIS CONTRACT. SPECIFIC WORK WILL BE ASSIGNED BY THE DEPARTMENT VIA WORK ORDERS AND THE DEPARTMENT WILL MAKE EVERY ATTEMPT TO MINIMIZE THE DISTANCE BETWEEN SUCCESSIVE LOCATIONS. THE CONTRACTOR MAY SUBMIT A REQUEST FOR ADDITIONAL MOT AND MOBILIZATION IN CONJUNCTION WITH ADDED LOCATIONS. THIS REQUEST WILL BE CONSIDERED ON THE BASIS OF EACH ADDITIONAL LOCATION. THE REQUEST FOR INITIAL EXPENSE/MOBILIZATION SHALL NOT EXCEED THE AMOUNT OF THE BID PRICE FOR 763000, DIVIDED BY THE NUMBER OF ORIGINAL CONTRACT LOCATIONS. THE REQUEST FOR MOT SHALL NOT EXCEED THE AMOUNT OF THE BID PRICE FOR 801500, DIVIDED BY THE NUMBER OF ORIGINAL CONTRACT LOCATIONS. FOR OPEN END CONTRACTS WITHOUT ORIGINAL LOCATIONS, BID ITEMS 763544-763552 SHALL BE FULL COMPENSATION FOR MOBILIZATION AND MOT.

EACH WORK ORDER ISSUED WILL HAVE CLEAR "START BY" DATE AND TIME ALLOCATED TO COMPLETE SAID WORK ORDER. ONCE TIME (CALENDAR DAYS) HAS BEEN ASSIGNED TO A WORK ORDER AND ISSUED, THE CONTRACTOR HAS 2 BUSINESS DAYS, NOT INCLUDING THE DAY OF ISSUANCE, TO DISPUTE THE TIME QUANTITY AND PROVIDE ADDITIONAL BACKUP DOCUMENTATION FOR WHY THE TIME QUANTITY IS NOT SUFFICIENT. A DETAILED BREAKDOWN OF LABOR/MATERIALS/EQUIPMENT ALONG WITH THE CONTRACTORS TIME ESTIMATE WILL BE REQUIRED; THIS INFORMATION MUST BE RECEIVED BY THE DEPARTMENT BY THE END OF THE 2<sup>ND</sup> BUSINESS DAY OR THE DEPARTMENT WILL CONSIDER THE CONTRACTOR IN AGREEMENT WITH THE TIME ESTIMATE. THE ENGINEER WILL EVALUATE ANY REQUEST FOR MODIFICATION TO THE TIME ESTIMATE AND AT THEIR SOLE DISCRETION DETERMINE IF ADDITIONAL TIME IS GRANTED. DISPUTING TIME QUANTITY DOES NOT CONSTITUTE A DELAY IN COMMENCEMENT OF A WORK ORDER. ISSUANCE OF EACH WORK ORDER CONSTITUTES THE NOTICE TO PROCEED WITH THE WORK DESCRIBED. FAILURE TO COMPLETE A WORK ORDER IN THE SPECIFIED TIME SHALL CONSTITUTE "FAILURE TO PURSUE THE WORK" AND SUBJECTS THE CONTRACTOR TO LIQUIDATED DAMAGES AS OUTLINED IN SUBSECTION 108.9 OF THE STANDARD SPECIFICATIONS BASED ON THE TOTAL VALUE OF THAT PARTICULAR WORK ORDER.

**GENERAL CONTRACT PLAN NOTES**

UPON ISSUANCE OF EACH WORK ORDER, THE CONTRACTOR SHALL SUBMIT THE REQUIRED COPIES OF A DETAILED PROGRESS SCHEDULE AS OUTLINED IN STANDARD SPECIFICATION 108.4 WITHIN 5 CALENDAR DAYS OF THE ISSUANCE OF WORK ORDER. DURING THE CONTRACT, THE CONTRACTOR SHALL SUBMIT TWO-WEEK (OR AS REQUIRED) "LOOK AHEAD" SCHEDULES TO THE AREA ENGINEER NO LATER THAN NOON OF EACH THURSDAY. DETAILS SHALL INCLUDE A DESCRIPTION OF EACH WORK ACTIVITY, THE PLANNED DAYS OF WORK, MULTIPLE CREWS OR SHIFTS, AND SCHEDULED WORKING HOURS. FAILURE TO COMPLY WILL RESULT IN A SUSPENSION OF ALL CONTRACT WORK WITH TIME CHARGES CONTINUING TO BE ASSESSED. THE PROGRESS SCHEDULE MUST ALSO BE UPDATED AND SUBMITTED TO THE DEPARTMENT AS CHANGES OR DELAYS OCCUR IN THE CONTRACT.

**SECTION 400**

9. UNLESS SPECIFIED, OVERLAY WIDTHS SHALL MATCH EXISTING WIDTHS.

10. THE COST OF CLIPPING BACK THE EDGES OF THE ROADWAY, SHOULDERS, AND THE FIRST 3' OF UNPAVED DRIVEWAY ENTRANCES, PICKING UP AND DISPOSING OF WASTE AND EXCESS MATERIAL, AND CLEANING THE EXISTING PAVEMENT PRIOR TO AN OVERLAY SHALL BE INCIDENTAL TO SECTION 401XXX. PREPARING UNPAVED DRIVEWAY ENTRANCES BEYOND THE FIRST 3' SHALL BE PAID UNDER THE APPROPRIATE CONTRACT ITEMS: 202000 AND/OR 30100X.

11. ALL PAVING, INCLUDING TURN LANES AND INTERSECTIONS, IS TO BE COMPLETED CURB TO CURB WITHIN SEVEN (7) CALENDAR DAYS FROM THE TIME THE AREA WAS MILLED. THIS RESTRICTION APPLIES TO EACH DAYS PAVEMENT MILLING OPERATION, NOT AN ENTIRE PROJECT LOCATION. FAILURE TO COMPLY WILL RESULT IN A SUSPENSION OF ALL OTHER CONTRACT WORK WITH TIME CHARGES CONTINUING TO BE ASSESSED.

12. IN ADDITION TO ITEM 401506 SPEED HUMP BEING UTILIZED FOR NEW SPEED HUMPS, IT SHALL ALSO INCLUDE REMOVE AND REPLACE SPEED HUMPS. UNLESS NOTED OTHERWISE, SPEED HUMPS SHALL BE MEASURED AND REPLACED AT THE SAME HEIGHT PRIOR TO CONSTRUCTION BUT SHALL NOT EXCEED 4". ALL SIGNING AND STRIPING SHALL CONFORM TO THE LATEST EDITION OF THE DE MUTCD AT THE TIME OF ADVERTISEMENT.

AT REMOVE AND REPLACE LOCATIONS, 401506 SHALL BE PAID AND THE REMOVAL SHALL BE INCIDENTAL TO THIS ITEM. SPEED HUMPS REMOVED AS PART OF THE MILLING/PAVING OPERATION, SCHEDULED TO BE PUT BACK, SHALL BE REPLACED WITHIN SEVEN (7) DAYS OF COMPLETION OF PAVING. FAILURE TO COMPLY WILL RESULT IN A SUSPENSION OF ALL OTHER CONTRACT WORK WITH TIME CHARGES CONTINUING TO BE ASSESSED. PAYMENT FOR THIS ITEM

**GENERAL CONTRACT PLAN NOTES**

SHALL INCLUDE PERMANENT STRIPING AND DELINEATOR POSTS. IF PERMANENT STRIPING CANNOT BE PLACED THE SAME DAY AS THE SPEED HUMP PLACEMENT, TEMPORARY STRIPING SHALL BE APPLIED THE SAME DAY.

13. PAVING WILL INCLUDE INTERSECTING STREETS FROM P.C. TO P.C.: MILLING AND PAVING OF INTERSECTING STREETS WILL NOT BE CONSIDERED FOR ENTRANCE, DRIVEWAY AND INTERSECTING STREET PAVEMENT SURCHARGE, NOR WILL DRIVEWAYS AND ENTRANCES.

14. FOR BITUMINOUS CONCRETE PATCH:

- FOR DRIVEWAY APRONS (BEHIND CURB) PLACE 2 LIFTS OF 2" BITUMINOUS CONCRETE TYPE C.
- FOR FINISHED PATCHES IN FRONT OF CURB, PLACE 2 LIFTS OF 2" BITUMINOUS CONCRETE TYPE C.
- FOR TEMPORARY PATCHES IN FRONT OF CURB, PLACE 2 LIFTS OF 2" OF BITUMINOUS CONCRETE TYPE C OR AS DIRECTED BY THE AREA ENGINEER.
- THE ENGINEER MAY CHANGE TYPE OF BITUMINOUS CONCRETE AND DEPTHS AT THEIR DISCRETION.

15. ALL JOINTS AND PAVEMENT CRACKS SHALL BE SEALED WITHIN 14 DAYS OF COMPLETION OF PAVING. FAILURE TO COMPLY WILL RESULT IN A SUSPENSION OF ALL OTHER CONTRACT WORK WITH TIME CHARGES CONTINUING TO BE ASSESSED.

**SECTION 500**

16. ITEM 701513 PCC PAVEMENT, 8" IS DESIGNATED FOR 8" VALLEY GUTTER. WHEN REPLACING VALLEY GUTTERS, PLEASE REFER TO CONTRACT PLAN DETAILS. DOWEL BARS, WIRE MESH REINFORCEMENT, BITUMINOUS SEAL, AND EXPANSION, PCC SAWCUTS, AND GABC UNDER THE PCC ARE INCIDENTAL TO VALLEY GUTTER ITEM (701513).

**SECTION 600**

17. DRAINAGE INLET GRATES ADJACENT TO THE ROAD, WITHIN THE PROJECT LIMITS, WHICH ARE NOT TYPE 1 SHALL BE REPLACED WITHIN 7 DAYS OF PAVING. THE NEED FOR ANY GRATE MODIFICATIONS OR FOR NEW FRAMES SHALL BE DETERMINED BY THE ENGINEER. ALL REPLACED GRATES/ FRAMES SHALL BE DELIVERED TO THE CANAL DISTRICT MAINTENANCE YARD, OR AS DIRECTED WITH THE COST OF DELIVERY INCIDENTAL TO 602100/602101, REPLACING DRAINAGE INLETS GRATES/FRAMES. FINAL PAYMENT FOR REPLACED GRATES/ FRAMES SHALL NOT BE MADE UNTIL RECEIPT OF DELIVERED MATERIALS IS PRODUCED AND SIGNED BY A DELDOT

---

**DEPARTMENT OF TRANSPORTATION**

---

**CONTRACT NUMBER- T202603109 CANAL  
COMMUNITY TRANSPORTATION FUND, NEW CASTLE IX, 2026**

**(CAD) PAGE 19 OF 73**

---

**GENERAL CONTRACT PLAN NOTES**

REPRESENTATIVE. PLEASE CALL 302-326-4523 TO GET DIRECTIONS PRIOR TO DROP-OFF.

18. CATCH BASIN ON GRADE (COG) INLET DIMENSIONS INCLUDE TROUGH LENGTH AND BOX DIMENSIONS VARY FROM 3'x5' to 6'x13". CONTRACTOR SHALL REMOVE THE COVER SLAB AND EXISTING MANHOLE FRAME AND LID, CLEAN MANHOLE FRAME AND LID AND SET ASIDE FOR REUSE. CONTRACTOR SHALL REPAIR THE WALLS WITH SOLID BRICK/BLOCK TO A DEPTH DETERMINED BY THE ENGINEER. A BUTYL SEAL SHALL BE APPLIED TO THE TOP COURSE. A 3/8" THICK STEEL SHEET WITH A 24" HOLE CUT ON CENTER SHALL BE PLACED ON TOP. FORMS SHALL BE CONSTRUCTED FOR 6" OF CLASS B CONCRETE TO BE PLACED ATOP THE STEEL SHEETING WITH #4 REBAR, 6" ON CENTER REUSING MANHOLE FRAME AND LID. WORK TO ADJUST OR REPAIR FLOW CHANNELS AND INSTALL STEPS IS EXCLUDED FROM DEPTH OF REPAIR PAYMENT ADJUSTMENTS. DEWATERING SHALL BE INCIDENTAL TO THE REPAIR.

COG INLET SHALL BE PAID FOR UNDER ITEM 602012 – DRAINAGE INLET, SPECIAL. THE DEPARTMENT WILL PAY THE QUANTITY OF ITEM 602012 AT THE CONTRACT UNIT PRICE. PRICE AND PAYMENT WILL CONSTITUTE FULL COMPENSATION.

19. CATCH BASINS WITH A MANHOLE SHALL BE CONVERTED TO A STANDARD CATCH BASIN AT THE DISCRETION OF THE ENGINEER. A 6" COVERSLAB WITH REBAR 6-8" ON CENTER AND MINIMUM OF 6" OF TOPSOIL ON TOP SHALL REPLACE MANHOLE. PAYMENT FOR ADDITIONAL WORK SHALL BE PAID AN ADDITIONAL QUANTITY OF 0.5 THE BID AMOUNT FOR ITEM 602130 OR 602131. WORK TO ADJUST OR REPAIR FLOW CHANNELS AND INSTALL STEPS IS EXCLUDED FROM DEPTH OF REPAIR PAYMENT ADJUSTMENTS. DEWATERING SHALL BE INCIDENTAL TO THE REPAIR.

20. WHEN ENCOUNTERING DELDOT STORMWATER MANHOLES WITHIN LIMITS OF PAVING, THOSE MANHOLES WILL BE ADJUSTED AND UPDATED AT THE DISCRETION OF THE ENGINEER. ITEMS 602102/602103 SHALL BE FULL COMPENSATION (FURNISH AND INSTALLING) THE NEW LIDS AND FRAMES.

21. WHEN ENCOUNTERING NEW CASTLE COUNTY SANITARY MANHOLES WITHIN THE LIMITS OF PAVING, THOSE MANHOLES WILL BE ADJUSTED AND UPDATED AT THE DISCRETION OF THE ENGINEER. THE LIDS AND FRAMES ARE PROVIDED BY NEW CASTLE COUNTY AT NO COST TO THE CONTRACTOR. OBTAINING, STORING, DELIVERING, AND PLACING THESE NEW LIDS AND FRAMES SHALL BE INCIDENTAL TO THE ADJUSTMENT ITEM 602132.

ANY ADJUSTMENTS TO THE AFOREMENTIONED MUNICIPALLY OWNED FACILITIES SHALL BE DONE IN ACCORDANCE WITH THE RESPECTIVE AGENCIES STANDARD SPECIFICATIONS, AS CONSTRUCTION WARRANTS.

**SECTION 700**

**GENERAL CONTRACT PLAN NOTES**

22. BUTT JOINTS SHALL BE CONSTRUCTED AT ALL INTERSECTING BITUMINOUS CONCRETE ROADS AND ANY OTHER LOCATIONS AS DIRECTED BY THE ENGINEER. BUTT JOINTS AT RAILROAD CROSSINGS AND AT BRIDGE OR DRAINAGE STRUCTURES NOT TO BE RESURFACED SHALL BE AS PER THE INCLUDED PLAN DETAIL. BUTT JOINTS CUT PRIOR TO THE DAY OF PAVEMENT OVERLAY SHALL BE RAMPED WITH BITUMINOUS CONCRETE TRM, IN MILLING AREAS, INCIDENTAL TO THE ITEM 762004 BUTT JOINT. ONLY BITUMINOUS CONCRETE WILL BE ALLOWED FOR THIS PURPOSE. BUTT JOINTS IN FULL MILL AREAS SHALL BE INCIDENTAL TO THE PAVEMENT MILLING ITEM (760010). SAWCUTS FOR BUTT JOINTS SHALL BE INCIDENTAL TO THE BUTT JOINT ITEM. ALL BITUMINOUS CONCRETE TRM SHALL BE REMOVED PRIOR TO THE PAVING OPERATION.

23. AFTER PAVEMENT MILLING, ALL TRANSVERSED VERTICAL DIFFERENCES, RAISED EDGES OF MANHOLES, DRAINAGE INLETS, WATER VALVE BOXES, ETC. SHALL BE RAMPED WITH BITUMINOUS CONCRETE TRM AT A 20:1 OR FLATTER SLOPE PRIOR TO OPENING THE ROADWAY TO TRAFFIC AND SHALL BE INCIDENTAL TO PAVEMENT MILLING. PAVEMENT MILLINGS OR COLD PATCH MATERIAL WILL NOT BE ALLOWED FOR THIS PURPOSE.

ALL ADJUSTMENTS SHALL BE MADE NOT MORE THAN SEVEN (7) CALENDAR DAYS PRIOR TO THE PLACEMENT OF THE FINAL COURSE OF BITUMINOUS CONCRETE, UNLESS DIRECTED BY THE ENGINEER. FAILURE TO COMPLY WILL RESULT IN A SUSPENSION OF ALL OTHER CONTRACT WORK WITH TIME CHARGES CONTINUING TO BE ASSESSED.

ALL BITUMINOUS CONCRETE TRM SHALL BE REMOVED PRIOR TO THE PAVING OPERATIONS. IF THE CONTRACTOR ELECTS TO ADJUST MANHOLES, DRAINAGE INLETS AND WATER VALVES AFTER THE FINAL COURSE OF PAVING, THIS WORK MUST BE COMPLETED WITHIN SEVEN (7) CALENDAR DAYS OF THE FINAL COURSE OF BITUMINOUS CONCRETE. FAILURE TO COMPLY WILL RESULT IN A SUSPENSION OF ALL OTHER CONTRACT WORK WITH TIME CHARGES CONTINUING TO BE ASSESSED.

24. THE CONTRACTOR SHALL TAKE CARE IN REMOVING PAVEMENT AROUND UTILITIES, BUTT JOINTS, CURBS, ETC. SO THAT EXISTING PAVEMENT BEYOND THE SPECIFIED DEPTHS IS NOT DAMAGED. ANY DAMAGE CAUSED BY THE CONTRACTOR'S OPERATIONS MAY RESULT IN PLACING LEVELING COURSES AT THE CONTRACTOR'S EXPENSE. THE REMOVAL AND CLEAN UP OF THE HOT MIX RESIDUE WEDGE REMAINING AFTER MILLING OPERATIONS SHALL BE INCIDENTAL TO THE MILLING ITEM. THE REMOVAL OF EXISTING RAISED PAVEMENT MARKERS (RPM'S) SHALL BE INCIDENTAL TO THE APPLICABLE MILLING AND/OR RECLAMATION ITEMS.

**GENERAL CONTRACT PLAN NOTES**

25. TAPER MILLING IS INTENDED FOR MILLING IN THE AREA OF FIXED STRUCTURES (I.E. CURBS, MANHOLES, ETC.) THE MILLED DEPTH AT THE STRUCTURE SHALL BE THE DEPTH OF THE PROPOSED OVERLAY AND 0" AT A DISTANCE OF +/- 6 ½ FEET FROM THE STRUCTURE. THE COMPUTED DEPTH FOR PAYMENT PURPOSES IS THE AVERAGE OF THE TWO DEPTHS.

UNLESS DIRECTED OTHERWISE BY THE AREA ENGINEER, ALL CUL-DE-SAC'S ON THIS CONTRACT SHALL BE TAPER MILLED AND WILL BE PAID AS ITEM 760011, TAPERMILL.

26. ON THIS CONTRACT FULL MILL AREAS WILL UTILIZE ITEM 760010 PAVEMENT MILLING, BITUMINOUS CONCRETE PAVEMENT (SY-IN). UNLESS OTHERWISE NOTED, ALL MILLING LOCATIONS ARE EXPECTED TO BE MILLED AT A 2" DEPTH. FOR AVERAGE MILLING DEPTHS OF 0.5" TO AN AVERAGE MILLING DEPTH OF 2.25", THE FULL MILL AREAS WILL BE PAID AT AN AVERAGE 2".

27. MILLING OF BITUMINOUS PAVEMENT IN PREPARTION FOR OVERLAY IS TO INCLUDE MILLING EXISTING CONCRETE PATCHES AND/OR COMPOSITE PAVING AND SHOULD BE CONSIDERED INCIDENTAL TO ITEM 760010, PAVEMENT MILLING, BITUMINOUS CONCRETE PAVEMENT.

28. ALL MILLED MATERIAL SHALL REMAIN THE PROPERTY OF THE CONTRACTOR UNLESS OTHERWISE STATED.

29. AT LOCATIONS THAT HAVE PCC REPLACEMENT, PAVING MUST BE COMPLETED WITHIN 90 CALENDAR DAYS FROM THE START OF THE PCC REPLACEMENT. BETWEEN OCTOBER 15TH AND NOVEMBER 30<sup>TH</sup>, PAVING MUST BE COMPLETED WITHIN 30 CALENDAR DAYS FROM THE START OF THE PCC REPLACEMENT. FAILURE TO COMPLY WILL RESULT IN A SUSPENSION OF ALL OTHER CONTRACT WORK WITH TIME CHARGES CONTINUING TO BE ASSESSED.

30. UPRIGHT PCC CURB UTILIZED FOR GRADE RETENTION 8" OR HIGHER WILL BE PAID AS 701013, TYPE 1-8 CURB.

31. EXCAVATION UP TO 2' IN FRONT OF CURB, ADA FACILITIES, DRAINAGE INLETS, AND VALLEY GUTTERS WILL BE INCIDENTAL TO THE CORRESPONDING ITEMS (701XXX, 705XXX, 602XXX, AND 501XXX). HOT MIX PLACED IN FRONT OF CURB WILL BE PAID UNDER ITEM 401XXX. USE OF CONCRETE AS FILL IN FRONT OF CURB WILL NOT BE ACCEPTED UNLESS DIRECTED BY THE ENGINEER. AT EACH LOCATION, BACKFILLING SHALL BE PERFORMED IMMEDIATELY UPON REMOVAL OF FORMS FOR CURB OR SIDEWALK. TOPSOIL, SEEDING, SEALING OF VALLEY GUTTERS, REMOVING OF FORMS, AND PARGING OF CATCH BASINS, SHALL BE COMPLETED WITHIN SEVEN (7) CALENDAR DAYS OF COMPLETION OF THE ITEM OF WORK. ITEM 908001, TOPSOIL, SHALL BE USED AS BACKFILL MATERIAL BEHIND CURB AND AROUND SIDEWALK OR/AS DIRECTED BY THE ENGINEER. TOPSOIL SHALL BE SCREENED/SIFTED SO AS NO MATERIAL GREATER THAN .5" SHOULD BE PRESENT IN MATERIAL USED FOR BACKFILL. EXCAVATED MATERIAL, NOT NEEDED ON THE

**GENERAL CONTRACT PLAN NOTES**

PROJECT, SHALL BE REMOVED FROM THE CONTRACT AT THE CONTRACTORS EXPENSE. FAILURE TO COMPLY WILL RESULT IN A SUSPENSION OF ALL OTHER CONTRACT WORK WITH THE CHARGES CONTINUING TO BE ASSESSED.

32. AS DIRECTED BY THE ENGINEER, THE CONTRACTOR SHALL PARTIALLY SAW AND FILL EXISTING CRACKED CURB AND/OR SIDEWALK WITH AN APPROVED SEALER. THIS WORK WILL BE INCIDENTAL TO ITEM 762001 SAWCUT - CONCRETE FULL DEPTH.

33. PERTAINING TO PCC CURB REMOVAL & PATCHING, SAWCUTTING IS TO BE PERFORMED PRIOR TO THE REMOVAL OF BITUMINOUS CONCRETE UNLESS APPROVAL IS GIVEN BY THE ENGINEERS REPRESENTATIVE.

34. BEFORE THE START OF A DAY'S PAVEMENT MILLING OR PAVING OPERATIONS AND WHERE THERE IS EXISTING STRIPING, THE CONTRACTOR SHALL BE REQUIRED TO PROVIDE PROOF THAT SUFFICIENT APPROVED STRIPING MATERIALS ARE ON HAND TO ENSURE STRIPING IS COMPLETE BEFORE TRAFFIC IS RETURNED TO THE ROADWAY.

35. ITEM 710370 STEEL CASING PIPE-4" IS DESIGNATED FOR ROOF DRAIN. WHEN REPLACING OR EXTENDING ROOF DRAINS, SUMP PUMP DRAINS, ETC. FROM RIGHT-OF-WAY TO CURBLINE, ITEM 710370 WILL BE UTILIZED REGARDLESS OF PIPE MATERIAL OR SIZE.

36. GAS VALVE, MONUMENT BOX, AND LAMPHOLE ADJUSTMENTS WILL BE PAID AS 710002, WATER VALVE ADJUSTMENTS.

37. REMOVAL OF ANY UNSUITABLE MATERIALS INCLUDING ROOTS AND VEGETATIVE MATTER DISCOVERED WITHIN OR DIRECTLY BELOW THE TEMPLATE OF PCC / GRANITE CURB, PEDESTRIAN FACILITIES, AND/OR PCC / BRICK SIDEWALKS SHALL BE INCIDENTAL TO THE CORRESPONDING ITEM.

38. TRASH, RUBBISH, DEBRIS, OR BRUSH THAT HAMPERS REPAIR/MAINTENANCE WORK IN THIS CONTRACT (AS DETERMINED BY THE ENGINEER), SHALL BE REMOVED WITHIN THE PROJECT LIMITS AND SHALL BE INCIDENTAL TO PAY ITEM 763000 (INITIAL EXPENSE/DEMOBILIZATION).

39. CLEARING AND GRUBBING INCLUDES OBTAINING WIDTH AND HEIGHT REQUIREMENTS FOR PAR AND CLEARING OF SIGHT DISTANCE (INCLUDING EXISTING FACILITIES AND SIGNS). CLEARING AND GRUBBING OF TREES, SHRUBS AND OTHER VEGETATION LESS THAN 6" IN DIAMETER SHALL BE INCIDENTAL TO ITEM 763000 (INITIAL EXPENSE/DEMOBILIZATION).

40. GRASS AND SOIL AREAS WITHIN THE STATE RIGHT-OF-WAY AND ADJACENT PRIVATE PROPERTY THAT HAS BEEN DAMAGED DURING CONTRACT OPERATIONS SHALL BE RESTORED WITH TOPSOIL, SEED AND MULCH AT THE CONTRATOR'S EXPENSE. WORK SHALL BE EXECUTED

**GENERAL CONTRACT PLAN NOTES**

IN ACCORDANCE WITH THE REQUIREMENTS FOR ITEM 908001 (TOPSOIL), ITEM 908016 (PERMANENT GRASS SEEDING SUBDIVISION), AND ITEM 908020 (EROSION CONTROL BLANKET MULCH). REPAIRS MUST BE COMPLETED WITHIN SEVEN (7) CALENDAR DAYS OF NOTIFICATION. FAILURE TO COMPLY WILL RESULT IN A SUSPENSION OF ALL OTHER CONTRACT WORK WITH TIME CHARGES CONTINUING TO BE ASSESSED.

**SECTION 800**

41. THE USE OF MILLINGS AND GABC IN THE TRAVEL WAY, TEMPORARY TRAVEL WAY, HIGH VOLUME ENTRANCES AND ACCESS RAMP FOR THE PURPOSE OF PROVIDING A TEMPORARY ROADWAY SURFACE, POTHOLE REPAIR, TAPERED EDGE FOR UTILITIES, BUTT JOINTS, AND LONGITUDINAL DROP-OFFS (MILLING AND PAVING OPERATIONS) IS PROHIBITED UNLESS IT IS OTHERWISE DESIGNATED TO BE USED IN THE CONTRACT PLANS. USE COLD PATCH, BITUMINOUS CONCRETE, BITUMINOUS CONCRETE WEDGE, OR TAPER MILL, AS NOTED IN THE CONTRACT DOCUMENTS OR APPROVED BY THE ENGINEER. PAYMENT FOR COLD PATCH, BITUMINOUS CONCRETE, OR BITUMINOUS CONCRETE WEDGE SHALL BE INCIDENTAL TO THE BITUMINOUS CONCRETE MILLING ITEM.

MILLINGS OR GABC SHALL BE USED AT THE FOLLOWING LOCATIONS WHERE ACCESS TO A BUSINESS RESIDENCE, OR EDGE DROP OFF NEEDS TO BE MAINTAINED UNLESS OTHERWISE NOTED IN THE PLANS OR DIRECTED BY THE ENGINEER TO USE BITUMINOUS CONCRETE OR COLD PATCH. ALL MILLING AND GABC WILL BE ROLLED AND COMPACTED TO HELP PREVENT THE MATERIAL FROM UNRAVELING.

- A. DRIVEWAYS
- B. ENTRANCES
- C. LOW VOLUME ACCESS RAMPS (IDENTIFIED IN THE CONTRACT DOCUMENTS)
- D. EDGE DROP-OFFS ADJACENT TO LIVE ROADWAY (LANE, SHOULDER, OR TURN LANE) AND THE PROPOSED ROAD CONSTRUCTION
- E. EDGE OF ROADWAY DROP-OFF

GRADING AND MAINTAINING BASE COURSE THAT IS BEING USED FOR ROADWAY WEDGE/FILLET BETWEEN TRAVEL LANES AND PAVEMENT BOX, EDGE OF TRAVEL WAY, DRIVEWAY OR ENTRANCE ACCESS SHALL BE INCIDENTAL TO ITEM 801500 (MAINTENANCE OF TRAFFIC). THE BASE COURSE MATERIAL SHALL BE PLACED AT NO GREATER THAN THE SLOPE SPECIFIED IN TABLE 6G-1 AND SHALL BE COMPACTED. EXCESS BASE COURSE MATERIAL SHALL BE PUSHED AHEAD AND USED IN

**GENERAL CONTRACT PLAN NOTES**

THE NEXT SEGMENT AND SHALL BE INCIDENTAL TO THE PARTICULAR BASE COURSE PAY ITEM. NO SEPARATE PAYMENT SHALL BE MADE FOR MILLINGS OR GABC TEMPORARY ROADWAY MATERIAL (TRM) USED TO PROTECT EDGE DROP-OFFS, UNLESS THE MATERIAL IS EVENTUALLY UTILIZED AS PART OF A PERMANENT ROADWAY AT WHICH TIME THE MATERIAL WOULD BE PAID FOR UNDER THE RESPECTIVE CONTRACT MATERIAL ITEM. VERTICAL DIFFERENCES SHALL BE CORRECTED IN ACCORDANCE WITH TABLE 6G-1 OF THE DELAWARE MUTCD.

42. LANE CLOSURES ON 3-DIGIT MAINTENANCE ROADS ARE PERMITTED ONLY BETWEEN THE HOURS OF 9:00 AM AND 3:00 PM, MONDAY - FRIDAY. ANY VARIANCE SHALL REQUIRE DISTRICT SAFETY OFFICERS APPROVAL.

43. MESSAGE BOARDS SHALL BE PLACED 10 DAYS IN ADVANCE OF THE WORK AND SHALL REMAIN IN PLACE FOR 5 DAYS AFTER THE START OF WORK. LOCATIONS OF MESSAGE BOARDS AND MESSAGES DISPLAYED SHALL BE REVIEWED AND APPROVED BY THE DISTRICT SAFETY OFFICER.

44. AT EACH LOCATION, THE CONTRACTOR SHALL NOTE ALL EXISTING PAVEMENT MARKINGS AND SUBMIT A DRAWING WHICH DEPICTS THE STRIPING PATTERN TO THE DEPARTMENT PRIOR TO THE START OF ANY WORK AT THE LOCATION.

AT THE END OF EACH DAY'S OPERATION AND BEFORE TRAFFIC IS RETURNED TO UNRESTRICTED ROADWAY USE, TEMPORARY MARKINGS SHALL BE UTILIZED AT LOCATIONS THAT REQUIRE PERMANENT MARKING. TEMPORARY PAVEMENT STRIPING MUST MATCH PERMANENT PAVEMENT STRIPING IN ALL REGARDS.

TEMPORARY PAVEMENT MARKINGS SHALL BE PAID AT THE APPLICABLE CONTRACT UNIT PRICE. THE CONTRACTOR IS RESPONSIBLE FOR MAINTAINING THE TEMPORARY MARKINGS IN GOOD CONDITION SUCH THAT THE PAVEMENT IS PROPERLY DELINEATED AT ALL TIMES. ANY REFRESHING OF THE TEMPORARY MARKINGS WILL BE AT THE CONTRACTOR'S EXPENSE.

FINAL PAVEMENT MARKINGS SHALL CONFORM TO ALL EXISTING PATTERNS AND SHALL BE PLACED WITHIN FIVE (5) CALENDER DAYS (MAXIMUM) AFTER PLACEMENT OF THE FINAL COURSE OF BITUMINOUS CONCRETE. IF THE CONTRACTOR FAILS TO DOCUMENT THE EXISTING PAVEMENT

**GENERAL CONTRACT PLAN NOTES**

MARKINGS IN AN ACCEPTABLE MANNER, HE SHALL BE REQUIRED TO PROVIDE AT HIS OWN EXPENSE, A NEW PAVEMENT MARKING PLAN SIGNED AND SEALED BY A PROFESSIONAL ENGINEER REGISTERED IN THE STATE OF DELAWARE.

ANY ERRONEOUS MARKING WILL NOT BE PAID FOR AND SHALL BE CORRECTED IMMEDIATELY AT THE CONTRACTOR'S EXPENSE. ERRONEOUS MARKINGS OR SHADOWS THAT EXCEED ONE (1) INCH IN WIDTH SHALL BE REMOVED BY EITHER SAND OR WATER BLASTING. NO OTHER REMOVAL METHODS WILL BE ALLOWED. A FLAT BLACK PAINT OR DRIVEWAY SEALER SHALL BE APPLIED IN THE AREA OF THE REMOVED MARKING TO MASK THE REPAIR. ANY DAMAGE TO THE PAVEMENT CAUSED BY REMOVAL OF ERRONEOUS MARKINGS SHALL BE REPAIRED / REPLACED TO THE SATISFACTION OF THE ENGINEER. FAILURE TO COMPLY WILL RESULT IN SUSPENSION OF ALL OTHER CONTRACT WORK WITH TIME CHARGES CONTINUING TO BE ASSESSED.

45. THE CONTRACTOR, WITH THE ENGINEER, SHALL INVENTORY ALL SIGNS ON ALL ROADS SUBJECT TO IMPROVEMENTS. NECESSARY SIGNS SHALL BE MAINTAINED IN OPERATION DURING CONSTRUCTION AND ANY OTHER SIGNS SHALL BE PROPERLY STORED WITH THE CONTRACTOR, WHO SHALL BE RESPONSIBLE FOR LOSS OR DAMAGE. IMMEDIATELY PRIOR TO FINAL INSPECTION, THE CONTRACTOR AND ENGINEER SHALL AGAIN INVENTORY THE TRAFFIC SIGNS AND ACCOUNT FOR ANY LOST OR DAMAGED SIGNS. LOST OR DAMAGED SIGNS, AT THE DISCRETION OF THE ENGINEER SHALL BE REPLACED IN KIND AT THE CONTRACTOR'S EXPENSE.

46. REGULATORY SIGNS REMOVED MUST BE REINSTALLED THE SAME DAY. IN ABSENCE OF A SIGN SCHEDULE, INSTALLATION OR REMOVAL OF TRAFFIC SIGN(S) AND SIGNPOST(S) WILL BE PAID AS ITEM 819003. THIS ITEM SHALL INCLUDE THE REMOVAL OF THE EXISTING SIGN(S) AND SIGNPOST(S), THE BORING/CREATION OF THE NEW HOLE, AND THE PLACEMENT OF THE SIGN(S) AND SIGNPOST(S) IN THE NEW LOCATION. ITEM 819003 WILL BE PAID ONE TIME PER POST AFTER FINAL INSTALLATION.

47. A FORMAL DETOUR WILL NOT BE NECESSARY ON THIS CONTRACT. THE CONTRACTOR MUST MAINTAIN LOCAL TRAFFIC WITHIN THE PROJECT LIMITS UTILIZING FLAGGERS. MAINTENANCE OF TRAFFIC DURING LANE CLOSURES AND/OR LANE SHIFTS SHALL CONFORM TO TYPICAL APPLICATIONS OF THE DELAWARE MUTCD. ANY VARIANCE SHALL REQUIRE DISTRICT SAFETY OFFICERS APPROVAL.

48. BEFORE WORK IS DONE AT ANY LOCATION, THE APPROPRIATE DISTRICT SAFETY OFFICER MUST APPROVE THE MOT FOR THAT LOCATION TWO WEEKS IN ADVANCE. ANY ANTICIPATED IMPACT TO TRAFFIC SIGNALS MUST BE REVIEWED BY THE DELDOT TRAFFIC SECTION PRIOR TO

**GENERAL CONTRACT PLAN NOTES**

CONSTRUCTION. THEY CAN BE CONTACTED AT 302-659-4061.

49. THE CONTRACTOR SHALL SUBMIT A TRAFFIC CONTROL PLAN, INCLUDING PEDESTRIAN AND BICYCLE FACILITIES, FOR ALL DEVICES THAT WILL BE UTILIZED PRIOR TO THE PRE-CONSTRUCTION MEETING. ALL TRAFFIC CONTROL DEVICES SHALL BE IN NEW OR REFURBISHED CONDITION AND MUST BE ON DELDOT'S APPROVED PRODUCTS LIST (APL). THE DEVICES SHALL BE APPROVED BY THE SAFETY SECTION PRIOR TO USE AND SHALL BE MAINTAINED IN GOOD CONDITION FOR THE DURATION OF THE CONTRACT.

50. ALL WORK SHALL BE PERFORMED IN A MANNER THAT WILL REASONABLY PROVIDE THE LEAST PRACTICABLE OBSTRUCTION TO ALL ROAD USERS, INCLUDING VEHICULAR, PEDESTRIAN AND BICYCLE TRAFFIC, AND SHALL CONFORM TO THE REQUIREMENTS OF THE 2011 DELAWARE MANUAL ON UNIFORM TRAFFIC CONTROL DEVICES, PART 6, INCLUDING ALL REVISIONS UP TO THE DATE OF ADVERTISEMENT FOR BIDS.

51. CURB RAMP AND/OR SIDEWALK CONSTRUCTION (NOT INCLUDING MEDIAN ISLANDS) SHALL BE COMPLETED DURING A SINGLE OPERATION. THE RAMP/SIDEWALK SHALL BE REMOVED AND PLACED BACK THE SAME NIGHT/DAY AND OPEN TO PEDESTRIAN TRAFFIC THE FOLLOWING DAY. THE USE OF A MONOLITHIC POUR SHALL BE PERMITTED WITH A BOND BREAKER TO BE PLACED AT THE BACK OF THE CURB AND EDGE OF SIDEWALK. IF THE CURB RAMP/SIDEWALK CANNOT BE COMPLETED IN A SINGLE OPERATION THE EXCAVATED AREA MUST BE TEMPORARILY BACKFILLED TO GRADE WITH COMPACTED MILLING MATERIAL ONLY. THIS TEMPORARY MATERIAL WILL BE INCIDENTAL TO THE CURB RAMP ITEM. THE DRESSING UP OF THE AREA BEING PAID AS A CURB RAMP WITH TOPSOIL AND SEED WILL BE PAID AT CONTRACT UNIT PRICES. THE CONTRACTOR SHALL MAINTAIN ACCESS TO AND ALONG PEDESTRIAN FACILITIES AT ALL TIMES DURING CONSTRUCTION. EARTH, STONE AND GRAVEL SURFACES ARE NOT ACCEPTABLE FOR PROVIDING PEDESTRIAN ACCESS. IF CURB RAMP CANNOT BE COMPLETED IN A SINGLE OPERATION AND PEDESTRIAN ROUTES ARE CLOSED OR BLOCKED, ALTERNATE PEDESTRIAN ACCESS SHALL BE PROVIDED USING TA-28 AND/OR TA-29 OF THE 2011 DELAWARE MANUAL ON UNIFORM TRAFFIC CONTROL DEVICES OR TO THE SATISFACTION OF THE ENGINEER. PEDESTRIAN DETOUR ROUTES OR ALTERNATE PEDESTRIAN FACILITIES SHALL CONSIST OF ADA COMPLIANT FACILITIES TO THE LEVEL OF WHICH EXISTS ON THE PEDESTRIAN ROUTE. THE COST FOR ANY PROVISIONS SHALL BE INCIDENTAL TO ITEM 801500 - MAINTENANCE OF TRAFFIC - ALL INCLUSIVE.

PEDESTRIAN MAINTENANCE OF TRAFFIC: THIS WORK SHALL CONSIST OF PROVIDING AND MAINTAINING AN ACCESSIBLE PEDESTRIAN ROUTE THROUGHOUT THE PROJECT'S LIMITS IN ACCORDANCE WITH *THE AMERICANS WITH DISABILITIES ACT OF 1990 (ADA) TITLE II, PARAGRAPH 35.130*.

THE CONTRACTOR SHALL BE REQUIRED TO REVIEW EACH CURB RAMP LOCATION AND SUBMIT THE APPROPRIATE MAINTENANCE OF TRAFFIC DETAIL AND DEVICES TO THE ENGINEER FOR EACH

**GENERAL CONTRACT PLAN NOTES**

LOCATION AT LEAST 2-WEEKS BEFORE CONSTRUCTION FOR REVIEW, COMMENT, AND APPROVAL BY THE DISTRICT SAFETY OFFICER.

THE FOLLOWING CONSIDERATIONS SHALL BE TAKEN INTO ACCOUNT WHEN ADDRESSING ACCESSIBLE PEDESTRIAN MAINTENANCE OF TRAFFIC:

- ALL PEDESTRIANS, INCLUDING PERSONS WITH DISABILITIES, SHALL BE PROVIDED WITH A REASONABLY SAFE, CONVENIENT AND ACCESSIBLE PATH THAT REPLICATES AS MUCH AS PRACTICABLE THE EXISTING PEDESTRIAN FACILITIES.
- MAINTAIN ACCESS TO ALL BUSINESS AND RESIDENTS AT ALL TIMES.
- PROVIDE PEDESTRIAN ACCESS THRU OR AROUND THE WORK ZONE. IF A DETOUR IS CHOSEN THE CONTRACTOR MUST SUBMIT THE DETOUR ROUTE TO THE ENGINEER FOR REVIEW AND APPROVAL. THE DETOUR ROUTE MUST MEET OR EXCEED THE CURRENT CONDITIONS.
- WORK SHOULD BE PHASED SO THAT ALL AREAS OF AN INTERSECTION/SIDEWALK PATH ARE NOT UNDER CONSTRUCTION AT THE SAME TIME UNLESS A CLEAR PATH IS PROVIDED AND IDENTIFIED.
- TRAFFIC CONTROL DEVICES AND OTHER CONSTRUCTION MATERIALS AND FEATURES SHALL NOT INTRUDE INTO THE USABLE WIDTH OF THE SIDEWALK, TEMPORARY PATHWAY OR OTHER PEDESTRIAN FACILITY.
- SIGNS AND OTHER DEVICES MOUNTED LOWER THAN 7 FT ABOVE THE TEMPORARY PEDESTRIAN PATHWAY SHALL NOT PROJECT MORE THAN 4 IN. INTO ACCESSIBLE PEDESTRIAN ROUTE.
- A SMOOTH, CONTINUOUS HARD SURFACE SHALL BE PROVIDED THROUGHOUT THE ENTIRE LENGTH AND WIDTH OF THE PEDESTRIAN ROUTE THROUGHOUT CONSTRUCTION. THERE SHALL BE NO CURBS OR VERTICAL ELEVATION CHANGES GREATER THAN ¼ IN. IN GRADE OR TERRAIN THAT COULD CAUSE TRIPPING OR BE A BARRIER TO WHEELCHAIR USE.

**SECTION 900**

52. EROSION CONTROL MULCH BLANKET SHALL BE USED IN ALL DISTURBED AREAS UNLESS DIRECTED OTHERWISE BY THE ENGINEER.

**ADDITIONAL PROJECT NOTES**

**GENERAL CONTRACT PLAN NOTES**

53. UNDERGROUND UTILITIES MAY BE PRESENT AT ALL LOCATIONS. THEREFORE, ALL STANDARD PRACTICES AND PROCEDURES REGARDING UTILITIES SHALL BE FOLLOWED. THE CONTRACTOR SHALL CONTACT MISS UTILITY OF DELAWARE PRIOR TO STARTING WORK. THE CONTRACTOR IS RESPONSIBLE FOR THE SUPPORT AND PROTECTION OF ALL UTILITIES WHEN EXCAVATING WHICH SHALL BE INCIDENTAL TO THE RESPECTIVE EXCAVATION ITEM(S). THE CONTRACTOR IS RESPONSIBLE FOR ENSURING PROPER CLEARANCES, INCLUDING SAFETY CLEARANCES, FROM OVERHEAD UTILITIES FOR CONSTRUCTION EQUIPMENT. THE CONTRACTOR IS ADVISED TO CHECK THE SITE FOR ACCESS PURPOSES FOR THEIR EQUIPMENT AND MAKE ARRANGEMENTS DIRECTLY WITH THE UTILITY COMPANIES FOR FIELD ADJUSTMENTS FOR ADEQUATE CLEARANCES, IF NECESSARY.

54. NO UTILITY RELOCATION INVOLVEMENT IS ANTICIPATED. SHOULD ANY CONFLICTS BE ENCOUNTERED DURING CONSTRUCTION REQUIRING ADJUSTMENT AND/OR RELOCATION OF THE AGENCIES' EXISTING FACILITIES, THE NECESSARY RELOCATION WORK SHALL BE ACCOMPLISHED BY THE RESPECTIVE AGENCIES' FORCES, AS DIRECTED BY THE DISTRICT ENGINEER. ANY ADJUSTMENTS AND/OR RELOCATIONS OF MUNICIPALLY OWNED FACILITIES SHALL BE DONE BY THE STATE'S CONTRACTOR IN ACCORDANCE WITH THE RESPECTIVE AGENCIES' STANDARD SPECIFICATIONS AS DIRECTED BY THE DISTRICT ENGINEER.

55. NO ENVIRONMENTAL PERMITS ARE REQUIRED FOR THIS WORK PROVIDED NO JURISDICTIONAL WETLANDS OR WATERS ARE IMPACTED. IF THERE IS ANY QUESTION AS TO WHETHER OR NOT A WATER OR WETLAND IS JURISDICTIONAL, CONTACT THE DEL DOT ENVIRONMENTAL SECTION AT 302-760-2264.

56. IT IS ANTICIPATED THAT ALL WORK WILL OCCUR WITHIN DELDOT'S EXISTING RIGHT OF WAY OR EASEMENT AREAS. SHOULD THE NEED OCCUR TO TRESPASS ONTO PRIVATE PROPERTY; IT WILL BE THE RESPONSIBILITY OF THE PROJECT MANAGER TO SECURE SUCH TRESPASS NEEDS.

57. NO WORK NEAR OR WITHIN RAILROAD RIGHT-OF-WAY IS ANTICIPATED. IF ANY RAILROAD PROPERTY OR FACILITIES ARE NEAR OR WITHIN THE PROPOSED LIMITS OF WORK OR IF THE PROPOSED WORK ENCROACHES UPON THE RAILROAD'S RIGHT-OF-WAY, THE CONTRACTOR SHALL BE RESPONSIBLE FOR OBTAINING THE REQUIRED CLEARANCES AND INSURANCES FOR EACH INVOLVED RAILROAD IN ACCORDANCE WITH THE APPROPRIATE DELDOT MAINTENANCE OF RAILROAD TRAFFIC ITEM. DELDOT'S RAILROAD SECTION MANAGER MUST BE CONTACTED AT (302) 659-4087 TO COORDINATE THE EXECUTION OF THE APPROPRIATE AGREEMENTS AND AUTHORIZATIONS REQUIRED FROM ANY RAILROAD COMPANY INVOLVED, INCLUDING COORDINATION FOR RAILROAD FLAGGING, IF NECESSARY. ELECTRONIC SUBMITTALS CAN BE SENT TO DOT\_RAILROAD@DELAWARE.GOV.

---

**DEPARTMENT OF TRANSPORTATION**

---

**CONTRACT NUMBER- T202603109 CANAL  
COMMUNITY TRANSPORTATION FUND, NEW CASTLE IX, 2026**

---

**(CAD) PAGE 29 OF 73**

**GENERAL CONTRACT PLAN NOTES**

58. THE PROJECT MANAGER SHALL BE RESPONSIBLE FOR COORDINATING WITH THE TRAFFIC SECTION RELATING TO ANY IMPACTS TO TRAFFIC SECTION FACILITIES (INCLUDING BUT NOT LIMITED TO TRAFFIC LOOPS, JUNCTION WELLS ETC.) AT LEAST 4 WEEKS IN ADVANCE OF THE START OF THE ACTIVITY. PRIOR TO INITIATING ANY WORK ON THIS CONTRACT (OR SITES), THE PROJECT MANAGER SHALL BE RESPONSIBLE FOR PREPARING AND SUBMITTING FOR APPROVAL OF THE SAFETY SECTION, A MAINTENANCE OF TRAFFIC PLAN. SUFFICIENT TIME SHALL BE PROVIDED FOR THE REVIEW AND APPROVAL OF THE PLAN. THE MAINTENANCE OF TRAFFIC PLAN SHALL INCLUDE PROPOSED TIME RESTRICTIONS ON THE CLOSURE OF TRAVEL LANES SUBJECT TO THE APPROVAL OF THE SAFETY SECTION. TRAFFIC LOOPS MUST BE PUT BACK WITHIN 7 DAYS OF PAVING, FAILURE TO COMPLY WILL RESULT IN A SUSPENSION OF ALL OTHER CONTRACT WORK WITH TIME CHARGES CONTINUING TO BE ASSESSED.

59. THE DEPARTMENT RESERVES THE RIGHT TO REQUEST AN EXTENSION OF THIS CONTRACT, WITH THE AGREEMENT OF THE CONTRACTOR, AT THE CURRENT CONTRACT PRICES.

Oct 2025

DELAWARE DEPARTMENT OF TRANSPORTATION

CONTRACT NUMBER- T202603109

(CAD) PAGE 30 OF 73

CANAL

Contract is for various locations throughout New Castle County.

DETAILS SHEET

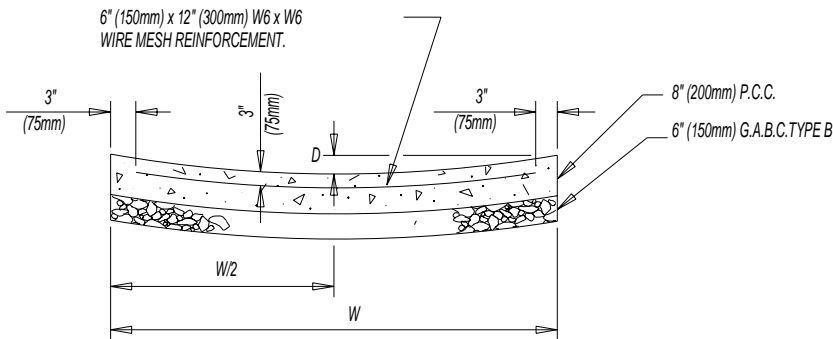
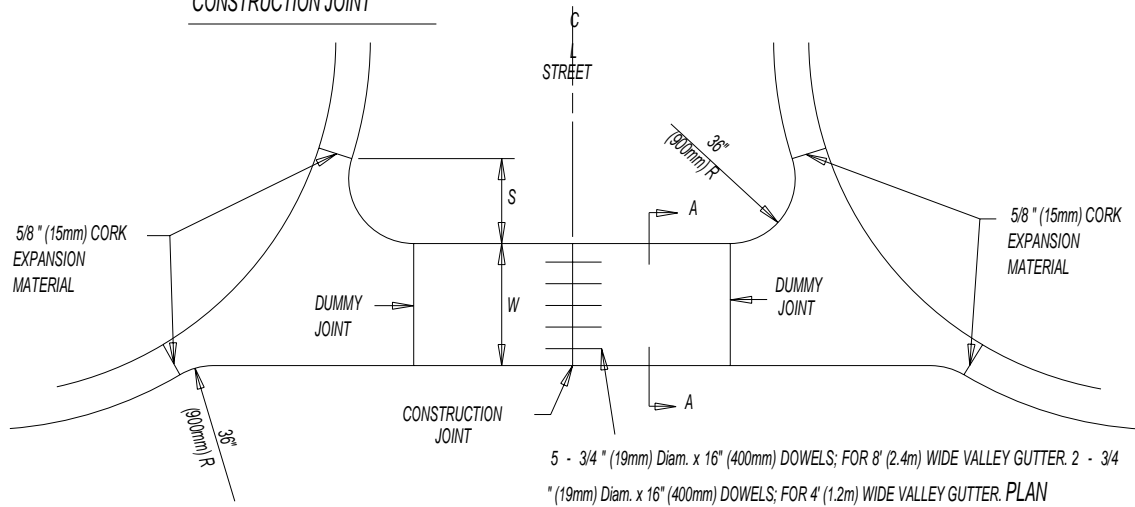
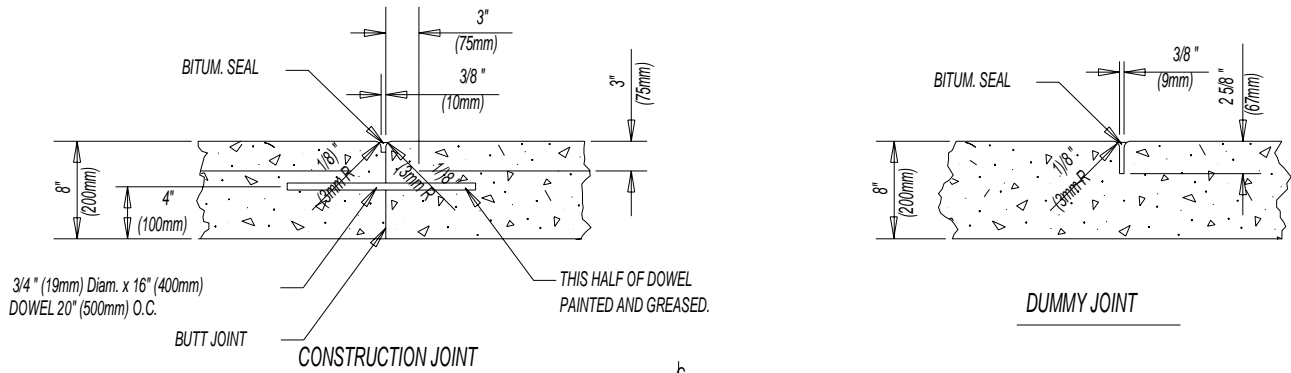

WIDTH W	DEPTH D	OFFSET S
8' (2.4m)	3" (75mm)	16" (405mm)
4' (1.2m)	1 1/2" (38mm)	23 1/2" (585mm)

P.C.C. VALLEY GUTTER

CANAL

Contract is for various locations throughout New Castle County.

DETAILS SHEET

SPEED HUMP

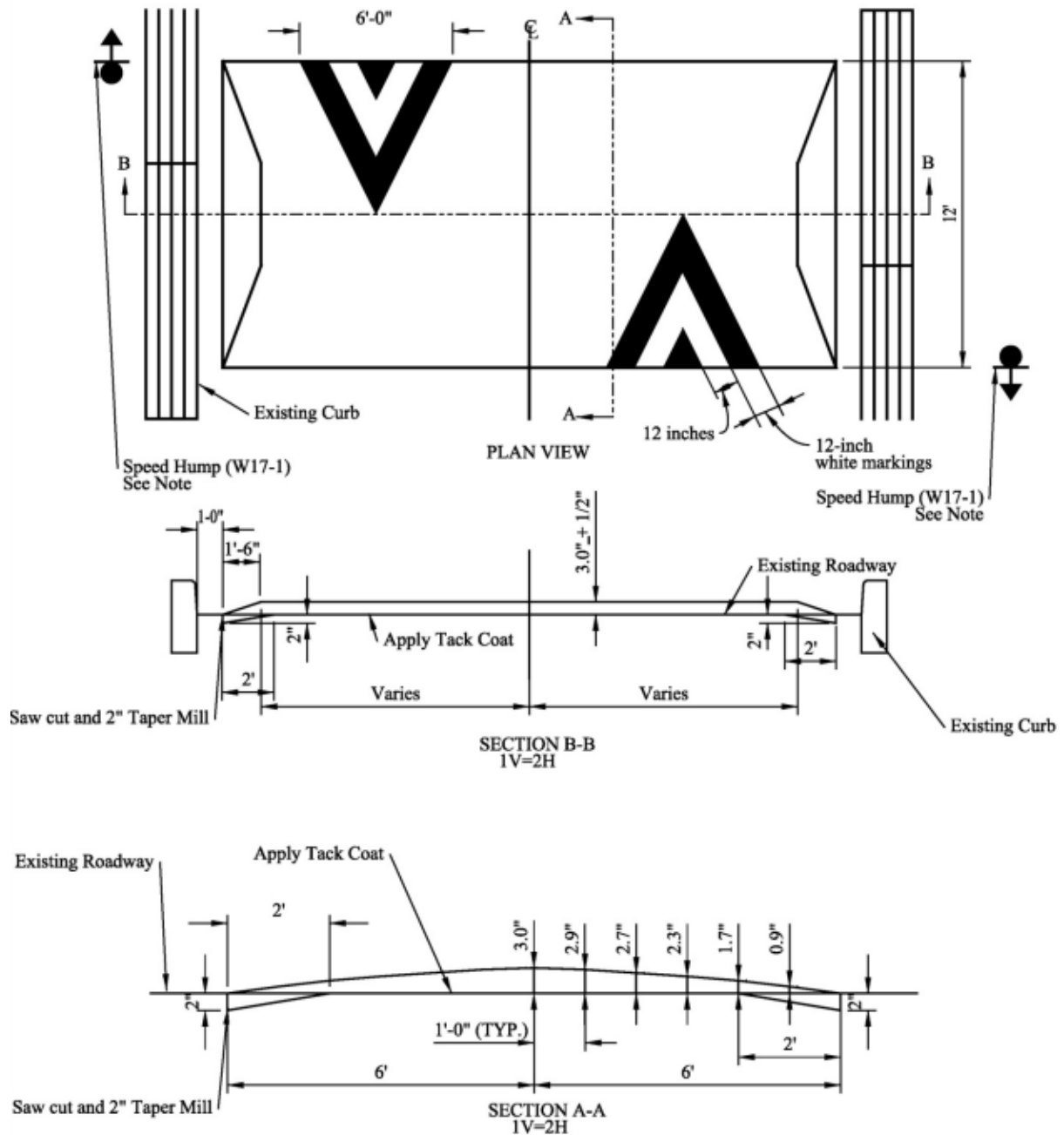

NOTE:  
 1. ALL SIGNING AND STRIPING SHALL CONFORM TO THE LATEST EDITION OF THE DE MUTCD.

DETAILS SHEET

PAVED AREA MANHOLE CONE SECTION DETAIL (NTS)

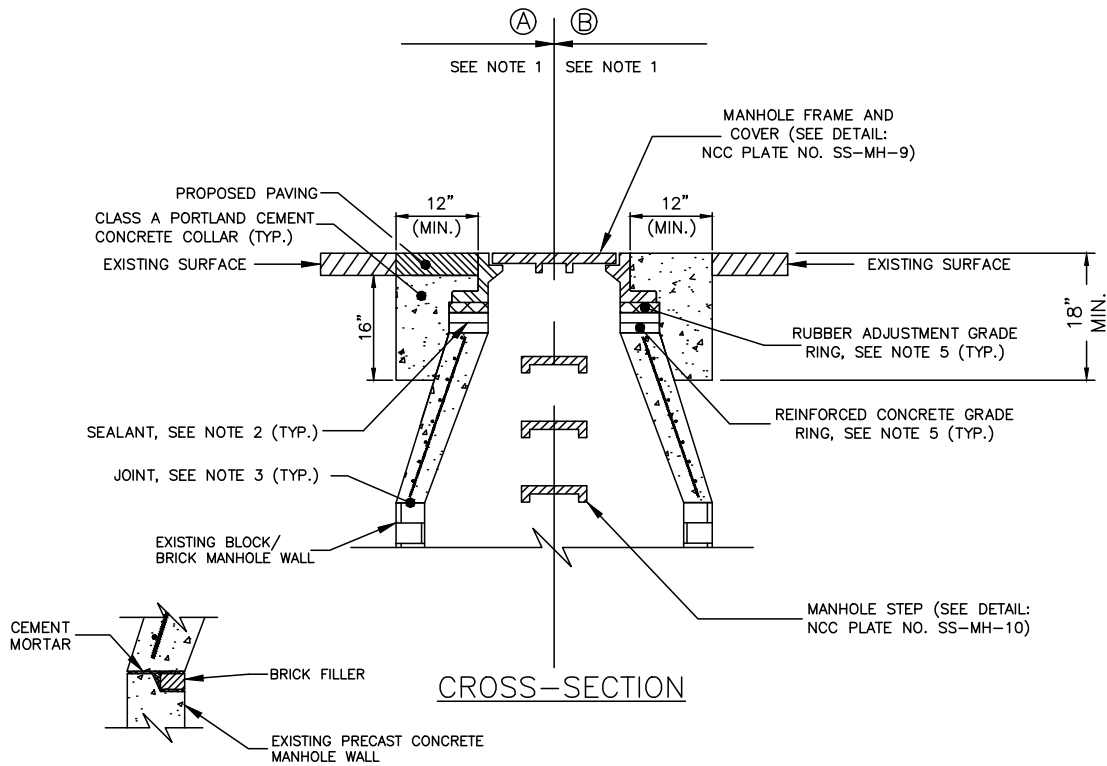

CROSS-SECTION OF JOINT AT PRECAST MANHOLE

NOTES:

1. AT THE DISCRETION OF THE CONTRACTOR, EITHER OPTION 'A' OR 'B' MAY BE INSTALLED ACCORDING TO DeIDOT SPECIFICATIONS.
  - (A) CONTRACTOR SHALL PAVE TO TOP OF MANHOLE FRAME TO MATCH EXISTING CONDITIONS PER DeIDOT STANDARD.
  - (B) CONTRACTOR WILL INSTALL SQUARE CONCRETE COLLAR, 12" FROM MANHOLE FRAME, TO TOP OF MANHOLE FRAME PER DeIDOT STANDARD.
2. SEAL EVERY JOINT IN MANHOLE 'CHIMNEY' BETWEEN THE FRAME AND RUBBER GRADE RING, BETWEEN EACH EACH GRADE RING AND BETWEEN GRADE RING AND TAPERED CONE SECTION USING ADHESIVE SEALANT CONFORMING TO ASTM D3498 AND SUITABLE FOR USE WITH MASONRY, RUBBER AND METAL MATERIALS. APPLY IN CONTINUOUS 1/2 INCH BEADS (MIN. TWO BEADS EVERY JOINT).
3. SEAL PRECAST CONE SECTION TO COMPETENT LAYER OF BLOCK OR BRICK USING CEMENT MORTAR. IF EXISTING MANHOLE IS PRE-CAST CONCRETE, SECURE BRICK IN GROOVED JOINT, WITH CEMENT MORTAR PRIOR TO PLACING CONE SECTION.
4. ADJUSTMENT RISERS OF ANY TYPE (I.E. BRICK) MAY NOT BE USED AS A SUBSTITUTE FOR GRADE RINGS.
5. HEIGHT OF RUBBER GRADE RING(S) NOT TO EXCEED 3". COMBINED HEIGHT OF GRADES RINGS NOT TO EXCEED 12" (SEE DETAIL: NCC PLATE NO. SS-MH-7).

This detail is subject to revision. Verify with New Castle County, Public Works, for correctness prior to implementation.

DELAWARE DEPARTMENT OF TRANSPORTATION

CONTRACT NUMBER- T202603109

(CAD) PAGE 33 OF 73

CANAL

Contract is for various locations throughout New Castle County.

DETAILS SHEET

GRADE RING DETAIL (NTS)

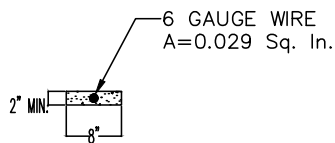
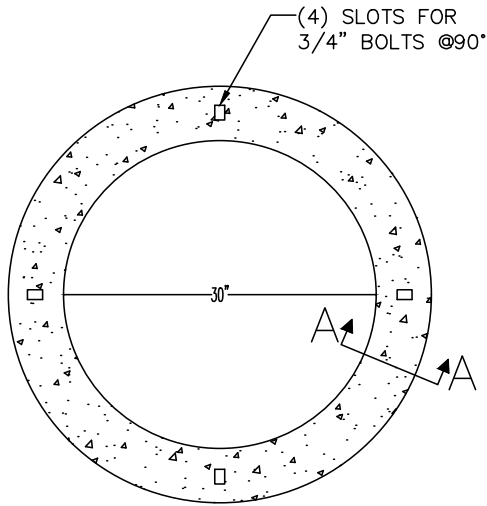

CROSS-SECTION A-A

REINFORCED CONCRETE  
GRADE RING

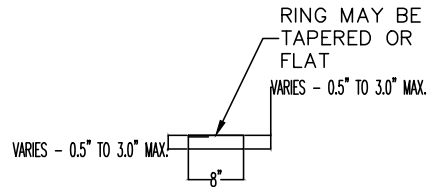
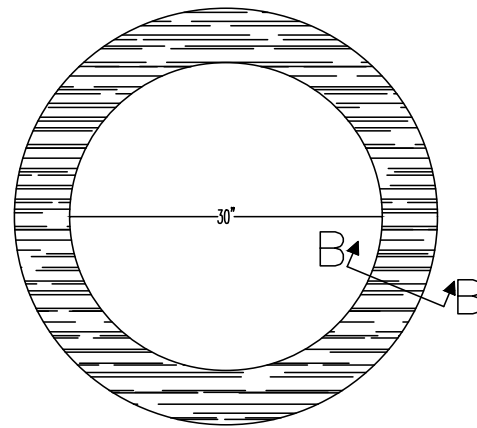

CROSS-SECTION B-B

RUBBER ADJUSTMENT  
GRADE RING

NOTES:

1. DESIGN MEETS REQUIREMENTS OF A.S.T.M. STANDARD C-478.
2. APPROXIMATE WEIGHT OF ONE REINFORCED CONCRETE GRADE RING:  
24"  $\phi$  - 140 lbs.  
30"  $\phi$  - 165 lbs.

NOTES:

1. SEAL EACH JOINT BETWEEN FRAME, RUBBER GRADE RING AND PRECAST GRADE RINGS USING ADHESIVE SEALANT CONFORMING TO ASTM D3498 AND SUITABLE FOR USE WITH MASONRY, RUBBER AND METAL MATERIALS. APPLY IN CONTINUOUS 1/2 INCH BEADS.
2. UNDER NO CIRCUMSTANCE SHALL A RUBBER GRADE RING BE MODIFIED OR ALTERED IN LIEU OF USING THE APPROPRIATE TAPERED GRADE RING.

This detail is subject to revision. Verify with New Castle County, Public Works, for correctness prior to implementation.



DELAWARE DEPARTMENT OF TRANSPORTATION

CONTRACT T202603109

(CAD) PAGE 35 OF 73

CANAL

COMMUNITY TRANSPORTATION FUND, NEW CASTLE IX, 2026

---

LOCATION 2                      BROOKBEND - HARMONY ROAD FROM BROWNLEAF RD TO ROSEWOOD DR  
LENGTH

**GENERAL IMPROVEMENTS**

REPLACE LANDSCAPED ISLANDS WITH PLAIN CONCRETE

**COMMENTS:**

REPLACE 3 LANDSCAPED ISLANDS WITH CONCRETE. REMOVAL AND DISPOSAL OF EXISTING PAVERS AND SHRUBBERY IS INCIDENTAL TO #202000. CONSTRUCTION RESTRICTED TO 9 AM TO 3 PM.

---

**MATERIAL ESTIMATE FOR LOCATION 2**

202000	EXCAVATION AND EMBANKMENT	119.00	C.Y.
301001	GABC	19.00	C.Y.
705002	PCC SIDEWALK, 6"	1,600.00	S.F.
762001	SAW CUTTING, CONCRETE, FULL DEPTH	480.00	L.F.
803001	PROVIDE AND MAINTAIN PORTABLE CHANGEABLE MESSAGE SIGN	24.00	EA-DY
808002	PROVIDE AND MAINTAIN TRUCK MOUNTED ATTENUATOR, TYPE II	4.00	EA-DY
811001	FLAGGER, NEW CASTLE COUNTY	286.00	HOUR
811013	FLAGGER, NEW CASTLE COUNTY, OVERTIME	29.00	HOUR
819003	INSTALL OR REMOVE TRAFFIC SIGNS	5.00	EACH



DELAWARE DEPARTMENT OF TRANSPORTATION

CONTRACT T202603109

(CAD) PAGE 37 OF 73

CANAL

COMMUNITY TRANSPORTATION FUND, NEW CASTLE IX, 2026

---

LOCATION 3                      **BROOKSIDE PARK - KENSINGTON LANE FROM KORDA DR (WEST INT) TO  
SOUTH CHAPEL STREET ROUTE SR72**

LENGTH      173.7360 m                      570.0000 L.F.

**GENERAL IMPROVEMENTS**

2" MILL AND OVERLAY(CURB WHERE NECESSARY)

**COMMENTS:**

2 RAMPS @ KENSINGTON CIRCLE

---

**MATERIAL ESTIMATE FOR LOCATION 3**

862006	PERMANENT PAVEMENT STRIPING, ALKYD-THERMOPLASTIC, SYMBOL/LEGEND	80.00	S.F.
905004	INLET SEDIMENT CONTROL, DRAINAGE INLET	5.00	EACH
908001	TOPSOIL	20.00	TON
908016	PERMANENT GRASS SEEDING, SUBDIVISION	120.00	S.Y.
908020	EROSION CONTROL BLANKET MULCH	120.00	S.Y.

**DELAWARE DEPARTMENT OF TRANSPORTATION**

**CONTRACT T202603109**

**(CAD) PAGE 38 OF 73**

**CANAL**

COMMUNITY TRANSPORTATION FUND, NEW CASTLE IX, 2026

**LOCATION 4 CHRISTINAS BRACE - MICHAELS LANE FROM TESSA COURT (INCLUDE INT)  
TO CUL-DE-SAC**

LENGTH 192.0240 m 630.0000 L.F.

**GENERAL IMPROVEMENTS**

2" MILL AND OVERLAY(CURB WHERE NECESSARY)

**COMMENTS:**

2 RAMPS @ TESSA.

**MATERIAL ESTIMATE FOR LOCATION 4**

202000	EXCAVATION AND EMBANKMENT	7.00	C.Y.
211001	REMOVAL OF PORTLAND CEMENT CONCRETE PAVEMENT, CURB AND SIDEWALK	99.00	S.Y.
301001	GABC	9.00	C.Y.
301002	GABC, PATCHING	10.00	C.Y.
401005	SUPERPAVE TYPE C, 9.5 mm, PG 64-22 (CARBONATE STONE)	250.00	TON
401029	SUPERPAVE TYPE C, 9.5 mm, PG 64-22, PATCHING	32.00	TON
401030	SUPERPAVE TYPE B, PG 64-22, PATCHING	10.00	TON
404001	BITUMINOUS CRACK AND JOINT SEALING LESS THAN 3/4-INCH WIDE	163.00	L.F.
602132	ADJUSTING AND REPAIRING EXISTING MANHOLE	2.00	EACH
701013	PCC CURB, TYPE 1-8	3.00	L.F.
701019	I.PCC CURB AND GUTTER, TYPE 2	150.00	L.F.
705001	PCC SIDEWALK, 4"	100.00	S.F.
705002	PCC SIDEWALK, 6"	90.00	S.F.
705008	PEDESTRIAN CONNECTION, TYPE 1	40.00	S.F.
705009	PEDESTRIAN CONNECTION, TYPE 2, 3, AND/OR 4	400.00	S.F.
705013	TRUNCATED DOME DETECTABLE WARNING SURFACE	20.00	S.F.
760010	PAVEMENT MILLING, BITUMINOUS CONCRETE PAVEMENT	2,900.00	SY-IN
760011	PAVEMENT MILLING, BITUMINOUS CONCRETE PAVEMENT, TAPER CUT	480.00	SY-IN
762000	SAW CUTTING, BITUMINOUS CONCRETE	275.00	L.F.
762001	SAW CUTTING, CONCRETE, FULL DEPTH	23.00	L.F.
811001	FLAGGER, NEW CASTLE COUNTY	125.00	HOUR
811013	FLAGGER, NEW CASTLE COUNTY, OVERTIME	16.00	HOUR
905004	INLET SEDIMENT CONTROL, DRAINAGE INLET	1.00	EACH
908001	TOPSOIL	14.00	TON
908016	PERMANENT GRASS SEEDING, SUBDIVISION	84.00	S.Y.

DELAWARE DEPARTMENT OF TRANSPORTATION

CONTRACT T202603109

(CAD) PAGE 39 OF 73

CANAL

COMMUNITY TRANSPORTATION FUND, NEW CASTLE IX, 2026

---

LOCATION 4 CHRISTINAS BRACE - MICHAELS LANE FROM TESSA COURT (INCLUDE INT)  
TO CUL-DE-SAC

LENGTH 192.0240 m 630.0000 L.F.

GENERAL IMPROVEMENTS

2" MILL AND OVERLAY(CURB WHERE NECESSARY)

COMMENTS:

2 RAMPS @ TESSA.

---

MATERIAL ESTIMATE FOR LOCATION 4

908020 EROSION CONTROL BLANKET MULCH

84.00 S.Y.

DELAWARE DEPARTMENT OF TRANSPORTATION

CONTRACT T202603109

(CAD) PAGE 40 OF 73

CANAL

COMMUNITY TRANSPORTATION FUND, NEW CASTLE IX, 2026

---

LOCATION 5 CHRISTINE MANOR WEST - DIXON DRIVE FROM VALLEY ROAD TO 1004  
DIXON DRIVE

LENGTH 167.6400 m 550.0000 L.F.

GENERAL IMPROVEMENTS  
2" MILL AND OVERLAY

COMMENTS:

---

MATERIAL ESTIMATE FOR LOCATION 5

202000	EXCAVATION AND EMBANKMENT	2.00	C.Y.
401005	SUPERPAVE TYPE C, 9.5 mm, PG 64-22 (CARBONATE STONE)	160.00	TON
401029	SUPERPAVE TYPE C, 9.5 mm, PG 64-22, PATCHING	1.00	TON
401030	SUPERPAVE TYPE B, PG 64-22, PATCHING	10.00	TON
404001	BITUMINOUS CRACK AND JOINT SEALING LESS THAN 3/4-INCH WIDE	300.00	L.F.
760010	PAVEMENT MILLING, BITUMINOUS CONCRETE PAVEMENT	2,500.00	SY-IN
762000	SAW CUTTING, BITUMINOUS CONCRETE	150.00	L.F.
811001	FLAGGER, NEW CASTLE COUNTY	61.00	HOUR
811013	FLAGGER, NEW CASTLE COUNTY, OVERTIME	9.00	HOUR

**DELAWARE DEPARTMENT OF TRANSPORTATION**

**CONTRACT T202603109**

**(CAD) PAGE 41 OF 73**

**CANAL**

COMMUNITY TRANSPORTATION FUND, NEW CASTLE IX, 2026

**LOCATION 6 COACH HILL - COACH HILL COURT FROM COACH HILL DRIVE (INCLUDES INT) SOUTH TO COACH HILL DRIVE CIHM**

LENGTH 83.8200 m 275.0000 L.F.

**GENERAL IMPROVEMENTS**

2" MILL AND OVERLAY(CURB WHERE NECESSARY)

**COMMENTS:**

INCLUDE INT. COACH HILL S.

**MATERIAL ESTIMATE FOR LOCATION 6**

202000	EXCAVATION AND EMBANKMENT	3.00	C.Y.
211001	REMOVAL OF PORTLAND CEMENT CONCRETE PAVEMENT, CURB AND SIDEWALK	29.00	S.Y.
301001	GABC	2.00	C.Y.
301002	GABC, PATCHING	5.00	C.Y.
401005	SUPERPAVE TYPE C, 9.5 mm, PG 64-22 (CARBONATE STONE)	100.00	TON
401029	SUPERPAVE TYPE C, 9.5 mm, PG 64-22, PATCHING	17.00	TON
401030	SUPERPAVE TYPE B, PG 64-22, PATCHING	5.00	TON
404001	BITUMINOUS CRACK AND JOINT SEALING LESS THAN 3/4-INCH WIDE	132.00	L.F.
602130	ADJUSTING AND REPAIRING EXISTING DRAINAGE INLET	5.00	EACH
602132	ADJUSTING AND REPAIRING EXISTING MANHOLE	1.00	EACH
701019	I.PCC CURB AND GUTTER, TYPE 2	120.00	L.F.
705002	PCC SIDEWALK, 6"	48.00	S.F.
710370	STEEL CASING PIPE, 4"	20.00	L.F.
760010	PAVEMENT MILLING, BITUMINOUS CONCRETE PAVEMENT	1,400.00	SY-IN
762000	SAW CUTTING, BITUMINOUS CONCRETE	170.00	L.F.
762001	SAW CUTTING, CONCRETE, FULL DEPTH	12.00	L.F.
811001	FLAGGER, NEW CASTLE COUNTY	58.00	HOUR
811013	FLAGGER, NEW CASTLE COUNTY, OVERTIME	9.00	HOUR
905004	INLET SEDIMENT CONTROL, DRAINAGE INLET	1.00	EACH
908001	TOPSOIL	3.00	TON
908016	PERMANENT GRASS SEEDING, SUBDIVISION	19.00	S.Y.
908020	EROSION CONTROL BLANKET MULCH	19.00	S.Y.



DELAWARE DEPARTMENT OF TRANSPORTATION

CONTRACT T202603109

(CAD) PAGE 43 OF 73

CANAL

COMMUNITY TRANSPORTATION FUND, NEW CASTLE IX, 2026

---

LOCATION 7 DUNLINDEN ACRES - KATHERINE AVENUE FROM FRANCES AVENUE  
(INCLUDE INT) TO EVELYN DRIVE

LENGTH 97.5360 m 320.0000 L.F.

**GENERAL IMPROVEMENTS**

2" MILL AND OVERLAY(CURB WHERE NECESSARY)

**COMMENTS:**

INCLUDE INT @ FRANCES. 4 RAMPS @ FRANCES. INCLUDE SPEED HUMP AS LIMIT.

---

**MATERIAL ESTIMATE FOR LOCATION 7**

762001	SAW CUTTING, CONCRETE, FULL DEPTH	60.00	L.F.
811001	FLAGGER, NEW CASTLE COUNTY	162.00	HOUR
811013	FLAGGER, NEW CASTLE COUNTY, OVERTIME	19.00	HOUR
905004	INLET SEDIMENT CONTROL, DRAINAGE INLET	1.00	EACH
908001	TOPSOIL	24.00	TON
908016	PERMANENT GRASS SEEDING, SUBDIVISION	144.00	S.Y.
908020	EROSION CONTROL BLANKET MULCH	144.00	S.Y.

**DELAWARE DEPARTMENT OF TRANSPORTATION**

**CONTRACT T202603109**

**(CAD) PAGE 44 OF 73**

**CANAL**

**COMMUNITY TRANSPORTATION FUND, NEW CASTLE IX, 2026**

**LOCATION 8                    ELMHURST - MANSION RD AND EMMA PL FROM MANSION RD  
   WILMINGTON, DE 19804 TO EMMA PL WILMINGTON, DE, 19804**

**LENGTH  
GENERAL IMPROVEMENTS  
   SIDEWALK REPAIRS**

**COMMENTS:  
   NE CORNER.**

**MATERIAL ESTIMATE FOR LOCATION 8**

<b>202000</b>	<b>EXCAVATION AND EMBANKMENT</b>	<b>2.00</b>	<b>C.Y.</b>
<b>211001</b>	<b>REMOVAL OF PORTLAND CEMENT CONCRETE PAVEMENT, CURB AND SIDEWALK</b>	<b>27.00</b>	<b>S.Y.</b>
<b>301001</b>	<b>GABC</b>	<b>4.00</b>	<b>C.Y.</b>
<b>301002</b>	<b>GABC, PATCHING</b>	<b>2.00</b>	<b>C.Y.</b>
<b>401029</b>	<b>SUPERPAVE TYPE C, 9.5 mm, PG 64-22, PATCHING</b>	<b>3.00</b>	<b>TON</b>
<b>404001</b>	<b>BITUMINOUS CRACK AND JOINT SEALING LESS THAN 3/4-INCH WIDE</b>	<b>1.00</b>	<b>L.F.</b>
<b>701013</b>	<b>PCC CURB, TYPE 1-8</b>	<b>2.00</b>	<b>L.F.</b>
<b>701019</b>	<b>I.PCC CURB AND GUTTER, TYPE 2</b>	<b>10.00</b>	<b>L.F.</b>
<b>705001</b>	<b>PCC SIDEWALK, 4"</b>	<b>50.00</b>	<b>S.F.</b>
<b>705002</b>	<b>PCC SIDEWALK, 6"</b>	<b>6.00</b>	<b>S.F.</b>
<b>705008</b>	<b>PEDESTRIAN CONNECTION, TYPE 1</b>	<b>20.00</b>	<b>S.F.</b>
<b>705009</b>	<b>PEDESTRIAN CONNECTION, TYPE 2, 3, AND/OR 4</b>	<b>200.00</b>	<b>S.F.</b>
<b>705013</b>	<b>TRUNCATED DOME DETECTABLE WARNING SURFACE</b>	<b>10.00</b>	<b>S.F.</b>
<b>762000</b>	<b>SAW CUTTING, BITUMINOUS CONCRETE</b>	<b>15.00</b>	<b>L.F.</b>
<b>762001</b>	<b>SAW CUTTING, CONCRETE, FULL DEPTH</b>	<b>2.00</b>	<b>L.F.</b>
<b>811001</b>	<b>FLAGGER, NEW CASTLE COUNTY</b>	<b>10.00</b>	<b>HOUR</b>
<b>811013</b>	<b>FLAGGER, NEW CASTLE COUNTY, OVERTIME</b>	<b>2.00</b>	<b>HOUR</b>
<b>908001</b>	<b>TOPSOIL</b>	<b>5.00</b>	<b>TON</b>
<b>908016</b>	<b>PERMANENT GRASS SEEDING, SUBDIVISION</b>	<b>26.00</b>	<b>S.Y.</b>
<b>908020</b>	<b>EROSION CONTROL BLANKET MULCH</b>	<b>26.00</b>	<b>S.Y.</b>

DELAWARE DEPARTMENT OF TRANSPORTATION

CONTRACT T202603109

(CAD) PAGE 45 OF 73

CANAL

COMMUNITY TRANSPORTATION FUND, NEW CASTLE IX, 2026

---

LOCATION 9 GLEN BERNE - WARDEL RD FROM 220 WARDEL RD TO 220 WARDEL RD

LENGTH 6.0960 m 20.0000 L.F.

GENERAL IMPROVEMENTS

FULL DEPTH PATCHING

COMMENTS:

FULL DEPTH PATCH

---

MATERIAL ESTIMATE FOR LOCATION 9

202000	EXCAVATION AND EMBANKMENT	11.00	C.Y.
301002	GABC, PATCHING	11.00	C.Y.
401029	SUPERPAVE TYPE C, 9.5 mm, PG 64-22, PATCHING	13.00	TON
401030	SUPERPAVE TYPE B, PG 64-22, PATCHING	20.00	TON
404001	BITUMINOUS CRACK AND JOINT SEALING LESS THAN 3/4-INCH WIDE	100.00	L.F.
762000	SAW CUTTING, BITUMINOUS CONCRETE	30.00	L.F.
811001	FLAGGER, NEW CASTLE COUNTY	4.00	HOUR
811013	FLAGGER, NEW CASTLE COUNTY, OVERTIME	1.00	HOUR

**DELAWARE DEPARTMENT OF TRANSPORTATION**

**CONTRACT T202603109**

**(CAD) PAGE 46 OF 73**

**CANAL**

**COMMUNITY TRANSPORTATION FUND, NEW CASTLE IX, 2026**

**LOCATION 10 GREENBRIDGE - GREENBRIDGE DRIVE FROM OLD NEWARK ROAD TO BRYANT COURT INCLUDES INT. TO NOSE OF MEDIAN.**

LENGTH 54.8640 m 180.0000 L.F.

**GENERAL IMPROVEMENTS**

2" MILL AND OVERLAY(CURB WHERE NECESSARY)

**COMMENTS:**

6 RAMPS @ BRYANT, 2 RAMPS @ OLD NEWARK RD. INCLUDES INT. TO NOSE OF MEDIAN @ BRYANT.

**MATERIAL ESTIMATE FOR LOCATION 10**

202000	EXCAVATION AND EMBANKMENT	6.00	C.Y.
211001	REMOVAL OF PORTLAND CEMENT CONCRETE PAVEMENT, CURB AND SIDEWALK	213.00	S.Y.
301001	GABC	20.00	C.Y.
301002	GABC, PATCHING	7.00	C.Y.
401005	SUPERPAVE TYPE C, 9.5 mm, PG 64-22 (CARBONATE STONE)	160.00	TON
401029	SUPERPAVE TYPE C, 9.5 mm, PG 64-22, PATCHING	22.00	TON
401030	SUPERPAVE TYPE B, PG 64-22, PATCHING	10.00	TON
404001	BITUMINOUS CRACK AND JOINT SEALING LESS THAN 3/4-INCH WIDE	134.00	L.F.
602132	ADJUSTING AND REPAIRING EXISTING MANHOLE	1.00	EACH
701013	PCC CURB, TYPE 1-8	9.00	L.F.
701019	I.PCC CURB AND GUTTER, TYPE 2	100.00	L.F.
705001	PCC SIDEWALK, 4"	300.00	S.F.
705002	PCC SIDEWALK, 6"	60.00	S.F.
705008	PEDESTRIAN CONNECTION, TYPE 1	120.00	S.F.
705009	PEDESTRIAN CONNECTION, TYPE 2, 3, AND/OR 4	1,600.00	S.F.
705013	TRUNCATED DOME DETECTABLE WARNING SURFACE	80.00	S.F.
760010	PAVEMENT MILLING, BITUMINOUS CONCRETE PAVEMENT	2,600.00	SY-IN
762000	SAW CUTTING, BITUMINOUS CONCRETE	200.00	L.F.
762001	SAW CUTTING, CONCRETE, FULL DEPTH	15.00	L.F.
802003	ARROW PANELS TYPE C	6.00	EA-DY
808002	PROVIDE AND MAINTAIN TRUCK MOUNTED ATTENUATOR, TYPE II	6.00	EA-DY
811001	FLAGGER, NEW CASTLE COUNTY	132.00	HOUR
811013	FLAGGER, NEW CASTLE COUNTY, OVERTIME	18.00	HOUR
860007	TEMPORARY PAVEMENT STRIPING, LATEX, SYMBOL/LEGEND	250.00	S.F.
862006	PERMANENT PAVEMENT STRIPING, ALKYD-THERMOPLASTIC, SYMBOL/LEGEND	250.00	S.F.

DELAWARE DEPARTMENT OF TRANSPORTATION

CONTRACT T202603109

(CAD) PAGE 47 OF 73

CANAL

COMMUNITY TRANSPORTATION FUND, NEW CASTLE IX, 2026

---

LOCATION 10 GREENBRIDGE - GREENBRIDGE DRIVE FROM OLD NEWARK ROAD TO BRYANT COURT INCLUDES INT. TO NOSE OF MEDIAN.

LENGTH 54.8640 m 180.0000 L.F.

**GENERAL IMPROVEMENTS**

2" MILL AND OVERLAY(CURB WHERE NECESSARY)

**COMMENTS:**

6 RAMPS @ BRYANT, 2 RAMPS @ OLD NEWARK RD. INCLUDES INT. TO NOSE OF MEDIAN @ BRYANT.

---

**MATERIAL ESTIMATE FOR LOCATION 10**

908001	TOPSOIL	28.00	TON
908016	PERMANENT GRASS SEEDING, SUBDIVISION	168.00	S.Y.
908020	EROSION CONTROL BLANKET MULCH	168.00	S.Y.

DELAWARE DEPARTMENT OF TRANSPORTATION

CONTRACT T202603109

(CAD) PAGE 48 OF 73

CANAL

COMMUNITY TRANSPORTATION FUND, NEW CASTLE IX, 2026

---

LOCATION 11 MARSHALLTON - NEW STREET FROM ~100' SOUTH OF JACKSON AVENUE  
(HOUSE #1312) TO ~100' SOUTH OF JACKSON AVENUE (HOUSE #1312)

LENGTH

GENERAL IMPROVEMENTS  
SPEED HUMP

COMMENTS:

1 SPEED HUMP @ #1312.

---

MATERIAL ESTIMATE FOR LOCATION 11

401506	SPEED HUMP	22.00	L.F.
404001	BITUMINOUS CRACK AND JOINT SEALING LESS THAN 3/4-INCH WIDE	44.00	L.F.
811001	FLAGGER, NEW CASTLE COUNTY	13.00	HOUR
811013	FLAGGER, NEW CASTLE COUNTY, OVERTIME	1.00	HOUR

DELAWARE DEPARTMENT OF TRANSPORTATION

CONTRACT T202603109

(CAD) PAGE 49 OF 73

CANAL

COMMUNITY TRANSPORTATION FUND, NEW CASTLE IX, 2026

---

LOCATION 12 MARSHALLTON - ORCHARD RD FROM ORCHARD RD TO ORCHARD RD

LENGTH 30.4800 m 100.0000 L.F.

GENERAL IMPROVEMENTS

FULL DEPTH PATCHING ONLY

COMMENTS:

2 PATCHES. 1) 40'x6' 2) 60'x6' APPROX.

---

MATERIAL ESTIMATE FOR LOCATION 12

202000	EXCAVATION AND EMBANKMENT	20.00	C.Y.
401029	SUPERPAVE TYPE C, 9.5 mm, PG 64-22, PATCHING	10.00	TON
401030	SUPERPAVE TYPE B, PG 64-22, PATCHING	20.00	TON
404001	BITUMINOUS CRACK AND JOINT SEALING LESS THAN 3/4-INCH WIDE	150.00	L.F.
762000	SAW CUTTING, BITUMINOUS CONCRETE	150.00	L.F.
811001	FLAGGER, NEW CASTLE COUNTY	20.00	HOUR
811013	FLAGGER, NEW CASTLE COUNTY, OVERTIME	1.00	HOUR

**DELAWARE DEPARTMENT OF TRANSPORTATION**

**CONTRACT T202603109**

**(CAD) PAGE 50 OF 73**

**CANAL**

**COMMUNITY TRANSPORTATION FUND, NEW CASTLE IX, 2026**

**LOCATION 13 MONTCLARE - MONTCLARE DRIVE FROM GHEEN ROAD TO CUL-DE-SAC**

**LENGTH 76.2000 m 250.0000 L.F.**

**GENERAL IMPROVEMENTS**

**2" MILL AND OVERLAY(CURB WHERE NECESSARY)**

**COMMENTS:**

**2 RAMPS @ GHEEN**

**MATERIAL ESTIMATE FOR LOCATION 13**

202000	EXCAVATION AND EMBANKMENT	11.00	C.Y.
211001	REMOVAL OF PORTLAND CEMENT CONCRETE PAVEMENT, CURB AND SIDEWALK	99.00	S.Y.
301001	GABC	9.00	C.Y.
301002	GABC, PATCHING	10.00	C.Y.
401005	SUPERPAVE TYPE C, 9.5 mm, PG 64-22 (CARBONATE STONE)	140.00	TON
401029	SUPERPAVE TYPE C, 9.5 mm, PG 64-22, PATCHING	32.00	TON
401030	SUPERPAVE TYPE B, PG 64-22, PATCHING	25.00	TON
404001	BITUMINOUS CRACK AND JOINT SEALING LESS THAN 3/4-INCH WIDE	89.00	L.F.
602132	ADJUSTING AND REPAIRING EXISTING MANHOLE	1.00	EACH
701013	PCC CURB, TYPE 1-8	3.00	L.F.
701019	I.PCC CURB AND GUTTER, TYPE 2	230.00	L.F.
705001	PCC SIDEWALK, 4"	100.00	S.F.
705002	PCC SIDEWALK, 6"	90.00	S.F.
705008	PEDESTRIAN CONNECTION, TYPE 1	40.00	S.F.
705009	PEDESTRIAN CONNECTION, TYPE 2, 3, AND/OR 4	400.00	S.F.
705013	TRUNCATED DOME DETECTABLE WARNING SURFACE	20.00	S.F.
760010	PAVEMENT MILLING, BITUMINOUS CONCRETE PAVEMENT	900.00	SY-IN
760011	PAVEMENT MILLING, BITUMINOUS CONCRETE PAVEMENT, TAPER CUT	500.00	SY-IN
762000	SAW CUTTING, BITUMINOUS CONCRETE	225.00	L.F.
762001	SAW CUTTING, CONCRETE, FULL DEPTH	23.00	L.F.
811001	FLAGGER, NEW CASTLE COUNTY	87.00	HOUR
811013	FLAGGER, NEW CASTLE COUNTY, OVERTIME	11.00	HOUR
908001	TOPSOIL	14.00	TON
908016	PERMANENT GRASS SEEDING, SUBDIVISION	84.00	S.Y.
908020	EROSION CONTROL BLANKET MULCH	84.00	S.Y.

**DELAWARE DEPARTMENT OF TRANSPORTATION**

**CONTRACT T202603109**

**(CAD) PAGE 51 OF 73**

**CANAL**

COMMUNITY TRANSPORTATION FUND, NEW CASTLE IX, 2026

**LOCATION 14 NONANTUM MILLS - KENNETH DRIVE FROM LENA COURT (INCLUDE INT) TO WILKERDEAN DRIVE EAST**

LENGTH 88.3920 m 290.0000 L.F.

**GENERAL IMPROVEMENTS**

2" MILL AND OVERLAY(CURB WHERE NECESSARY)

**COMMENTS:**

INCLUDE INT @ LENA. 2 RAMPS @ LENA. 2 RAMPS @ WILKERDEAN.

**MATERIAL ESTIMATE FOR LOCATION 14**

202000	EXCAVATION AND EMBANKMENT	8.00	C.Y.
211001	REMOVAL OF PORTLAND CEMENT CONCRETE PAVEMENT, CURB AND SIDEWALK	139.00	S.Y.
301001	GABC	14.00	C.Y.
301002	GABC, PATCHING	2.00	C.Y.
401005	SUPERPAVE TYPE C, 9.5 mm, PG 64-22 (CARBONATE STONE)	100.00	TON
401029	SUPERPAVE TYPE C, 9.5 mm, PG 64-22, PATCHING	6.00	TON
401030	SUPERPAVE TYPE B, PG 64-22, PATCHING	25.00	TON
404001	BITUMINOUS CRACK AND JOINT SEALING LESS THAN 3/4-INCH WIDE	2.00	L.F.
701013	PCC CURB, TYPE 1-8	6.00	L.F.
701023	I.PCC CURB AND GUTTER, TYPE 3-8	20.00	L.F.
705001	PCC SIDEWALK, 4"	200.00	S.F.
705002	PCC SIDEWALK, 6"	12.00	S.F.
705008	PEDESTRIAN CONNECTION, TYPE 1	80.00	S.F.
705009	PEDESTRIAN CONNECTION, TYPE 2, 3, AND/OR 4	1,200.00	S.F.
705013	TRUNCATED DOME DETECTABLE WARNING SURFACE	60.00	S.F.
760010	PAVEMENT MILLING, BITUMINOUS CONCRETE PAVEMENT	1,500.00	SY-IN
762000	SAW CUTTING, BITUMINOUS CONCRETE	30.00	L.F.
762001	SAW CUTTING, CONCRETE, FULL DEPTH	3.00	L.F.
811001	FLAGGER, NEW CASTLE COUNTY	72.00	HOUR
811013	FLAGGER, NEW CASTLE COUNTY, OVERTIME	9.00	HOUR
908001	TOPSOIL	17.00	TON
908016	PERMANENT GRASS SEEDING, SUBDIVISION	101.00	S.Y.
908020	EROSION CONTROL BLANKET MULCH	101.00	S.Y.

DELAWARE DEPARTMENT OF TRANSPORTATION

CONTRACT T202603109

(CAD) PAGE 52 OF 73

CANAL

COMMUNITY TRANSPORTATION FUND, NEW CASTLE IX, 2026

---

LOCATION 15 OLD MILL MANOR - MILLWRIGHT DR FROM 62 MILLWRIGHT DR TO 62  
MILLWRIGHT DR

LENGTH

GENERAL IMPROVEMENTS

CURB AND GUTTER REPAIRS

COMMENTS:

CURB IN FRONT OF DRIVEWAY TO APPROX. 30 LF EAST OF DRIVEWAY.

---

MATERIAL ESTIMATE FOR LOCATION 15

202000	EXCAVATION AND EMBANKMENT	2.00	C.Y.
211001	REMOVAL OF PORTLAND CEMENT CONCRETE PAVEMENT, CURB AND SIDEWALK	29.00	S.Y.
301001	GABC	2.00	C.Y.
301002	GABC, PATCHING	5.00	C.Y.
401029	SUPERPAVE TYPE C, 9.5 mm, PG 64-22, PATCHING	16.00	TON
404001	BITUMINOUS CRACK AND JOINT SEALING LESS THAN 3/4-INCH WIDE	8.00	L.F.
701019	I.PCC CURB AND GUTTER, TYPE 2	80.00	L.F.
705002	PCC SIDEWALK, 6"	48.00	S.F.
762000	SAW CUTTING, BITUMINOUS CONCRETE	120.00	L.F.
762001	SAW CUTTING, CONCRETE, FULL DEPTH	12.00	L.F.
811001	FLAGGER, NEW CASTLE COUNTY	13.00	HOUR
811013	FLAGGER, NEW CASTLE COUNTY, OVERTIME	1.00	HOUR
908001	TOPSOIL	3.00	TON
908016	PERMANENT GRASS SEEDING, SUBDIVISION	19.00	S.Y.
908020	EROSION CONTROL BLANKET MULCH	19.00	S.Y.

DELAWARE DEPARTMENT OF TRANSPORTATION

CONTRACT T202603109

(CAD) PAGE 53 OF 73

CANAL

COMMUNITY TRANSPORTATION FUND, NEW CASTLE IX, 2026

---

LOCATION 16                      RAMSEY RIDGE - DEWBERRY DRIVE FROM WINEBERRY DRIVE (INCLUDE  
INT) TO END

LENGTH      358.1400 m                      1175.0000 L.F.

GENERAL IMPROVEMENTS  
2" MILL AND OVERLAY

COMMENTS:

INCLUDE INT @ WINEBERRY.

---

MATERIAL ESTIMATE FOR LOCATION 16

401005	SUPERPAVE TYPE C, 9.5 mm, PG 64-22 (CARBONATE STONE)	375.00	TON
401029	SUPERPAVE TYPE C, 9.5 mm, PG 64-22, PATCHING	1.00	TON
401030	SUPERPAVE TYPE B, PG 64-22, PATCHING	25.00	TON
404001	BITUMINOUS CRACK AND JOINT SEALING LESS THAN 3/4-INCH WIDE	604.00	L.F.
760010	PAVEMENT MILLING, BITUMINOUS CONCRETE PAVEMENT	5,900.00	SY-IN
762000	SAW CUTTING, BITUMINOUS CONCRETE	302.00	L.F.
811001	FLAGGER, NEW CASTLE COUNTY	140.00	HOUR
811013	FLAGGER, NEW CASTLE COUNTY, OVERTIME	15.00	HOUR

DELAWARE DEPARTMENT OF TRANSPORTATION

CONTRACT T202603109

(CAD) PAGE 54 OF 73

CANAL

COMMUNITY TRANSPORTATION FUND, NEW CASTLE IX, 2026

---

**LOCATION 17**                      **ROBSCOTT MANOR - BOBBY DRIVE FROM BETWEEN HOUSE #4 AND #6 TO  
BETWEEN HOUSE #4 AND #6**

LENGTH      3.6576 m                                      12.0000 L.F.

**GENERAL IMPROVEMENTS**  
SPEED HUMP

COMMENTS:

---

**MATERIAL ESTIMATE FOR LOCATION 17**

401506	SPEED HUMP	32.00	L.F.
404001	BITUMINOUS CRACK AND JOINT SEALING LESS THAN 3/4-INCH WIDE	64.00	L.F.
811001	FLAGGER, NEW CASTLE COUNTY	19.00	HOUR
811013	FLAGGER, NEW CASTLE COUNTY, OVERTIME	2.00	HOUR

**DELAWARE DEPARTMENT OF TRANSPORTATION**

**CONTRACT T202603109**

**(CAD) PAGE 55 OF 73**

**CANAL**

COMMUNITY TRANSPORTATION FUND, NEW CASTLE IX, 2026

**LOCATION 18 ROBSCOTT MANOR - GLYN DRIVE FROM JANICE DRIVE TO PARKING LOT**

**LENGTH 99.0600 m 325.0000 L.F.**

**GENERAL IMPROVEMENTS**

2" MILL AND OVERLAY(CURB WHERE NECESSARY)

**COMMENTS:**

INCLUDES INTERSECTION W/ JANICE - 4 RAMPS @ JANICE. 1 RAMP @ SCHOOL SIDEWALK.  
WORK TO BE COMPLETED DURING "SCHOOLS OUT" PERIOD.

**MATERIAL ESTIMATE FOR LOCATION 18**

211001	REMOVAL OF PORTLAND CEMENT CONCRETE PAVEMENT, CURB AND SIDEWALK	152.00	S.Y.
301001	GABC	13.00	C.Y.
301002	GABC, PATCHING	7.00	C.Y.
401005	SUPERPAVE TYPE C, 9.5 mm, PG 64-22 (CARBONATE STONE)	110.00	TON
401029	SUPERPAVE TYPE C, 9.5 mm, PG 64-22, PATCHING	22.00	TON
401030	SUPERPAVE TYPE B, PG 64-22, PATCHING	20.00	TON
401506	SPEED HUMP	22.00	L.F.
404001	BITUMINOUS CRACK AND JOINT SEALING LESS THAN 3/4-INCH WIDE	35.00	L.F.
602130	ADJUSTING AND REPAIRING EXISTING DRAINAGE INLET	1.00	EACH
602132	ADJUSTING AND REPAIRING EXISTING MANHOLE	1.00	EACH
701013	PCC CURB, TYPE 1-8	80.00	L.F.
701018	I.PCC CURB AND GUTTER, TYPE 1-8	30.00	L.F.
701019	I.PCC CURB AND GUTTER, TYPE 2	80.00	L.F.
705001	PCC SIDEWALK, 4"	44.00	S.F.
705002	PCC SIDEWALK, 6"	88.00	S.F.
705008	PEDESTRIAN CONNECTION, TYPE 1	40.00	S.F.
705009	PEDESTRIAN CONNECTION, TYPE 2, 3, AND/OR 4	1,000.00	S.F.
705013	TRUNCATED DOME DETECTABLE WARNING SURFACE	50.00	S.F.
710002	ADJUST WATER VALVE BOXES	4.00	EACH
760010	PAVEMENT MILLING, BITUMINOUS CONCRETE PAVEMENT	1,740.00	SY-IN
762000	SAW CUTTING, BITUMINOUS CONCRETE	165.00	L.F.
762001	SAW CUTTING, CONCRETE, FULL DEPTH	17.00	L.F.
811001	FLAGGER, NEW CASTLE COUNTY	125.00	HOUR
811013	FLAGGER, NEW CASTLE COUNTY, OVERTIME	11.00	HOUR
860007	TEMPORARY PAVEMENT STRIPING, LATEX, SYMBOL/LEGEND	350.00	S.F.
862006	PERMANENT PAVEMENT STRIPING, ALKYD-THERMOPLASTIC, SYMBOL/LEGEND	350.00	S.F.

DELAWARE DEPARTMENT OF TRANSPORTATION

CONTRACT T202603109

(CAD) PAGE 56 OF 73

CANAL

COMMUNITY TRANSPORTATION FUND, NEW CASTLE IX, 2026

---

LOCATION 18 ROBSCOTT MANOR - GLYN DRIVE FROM JANICE DRIVE TO PARKING LOT

LENGTH 99.0600 m 325.0000 L.F.

GENERAL IMPROVEMENTS

2" MILL AND OVERLAY(CURB WHERE NECESSARY)

COMMENTS:

INCLUDES INTERSECTION W/ JANICE - 4 RAMPS @ JANICE. 1 RAMP @ SCHOOL SIDEWALK.  
WORK TO BE COMPLETED DURING "SCHOOLS OUT" PERIOD.

---

MATERIAL ESTIMATE FOR LOCATION 18

905004	INLET SEDIMENT CONTROL, DRAINAGE INLET	1.00	EACH
908001	TOPSOIL	20.00	TON
908016	PERMANENT GRASS SEEDING, SUBDIVISION	122.00	S.Y.
908020	EROSION CONTROL BLANKET MULCH	122.00	S.Y.

**DELAWARE DEPARTMENT OF TRANSPORTATION**

**CONTRACT T202603109**

**(CAD) PAGE 57 OF 73**

**CANAL**

**COMMUNITY TRANSPORTATION FUND, NEW CASTLE IX, 2026**

**LOCATION 19 ROBSCOTT MANOR - JANICE DRIVE FROM ALWYN ROAD (INCLUDE INT) TO ALDERSHOT DRIVE (INCLUDE INT)**

LENGTH 114.3000 m 375.0000 L.F.

**GENERAL IMPROVEMENTS**

2" MILL AND OVERLAY(CURB WHERE NECESSARY)

**COMMENTS:**

INCLUDE BOTH INT. 6 RAMPS @ ALDERSHOT.

**MATERIAL ESTIMATE FOR LOCATION 19**

202000	EXCAVATION AND EMBANKMENT	7.00	C.Y.
211001	REMOVAL OF PORTLAND CEMENT CONCRETE PAVEMENT, CURB AND SIDEWALK	225.00	S.Y.
301001	GABC	20.00	C.Y.
301002	GABC, PATCHING	11.00	C.Y.
401005	SUPERPAVE TYPE C, 9.5 mm, PG 64-22 (CARBONATE STONE)	150.00	TON
401029	SUPERPAVE TYPE C, 9.5 mm, PG 64-22, PATCHING	32.00	TON
401030	SUPERPAVE TYPE B, PG 64-22, PATCHING	8.00	TON
401506	SPEED HUMP	22.00	L.F.
404001	BITUMINOUS CRACK AND JOINT SEALING LESS THAN 3/4-INCH WIDE	233.00	L.F.
602130	ADJUSTING AND REPAIRING EXISTING DRAINAGE INLET	1.00	EACH
602132	ADJUSTING AND REPAIRING EXISTING MANHOLE	1.00	EACH
701013	PCC CURB, TYPE 1-8	9.00	L.F.
701018	I.PCC CURB AND GUTTER, TYPE 1-8	50.00	L.F.
701019	I.PCC CURB AND GUTTER, TYPE 2	100.00	L.F.
705001	PCC SIDEWALK, 4"	300.00	S.F.
705002	PCC SIDEWALK, 6"	90.00	S.F.
705008	PEDESTRIAN CONNECTION, TYPE 1	120.00	S.F.
705009	PEDESTRIAN CONNECTION, TYPE 2, 3, AND/OR 4	1,200.00	S.F.
705013	TRUNCATED DOME DETECTABLE WARNING SURFACE	60.00	S.F.
760010	PAVEMENT MILLING, BITUMINOUS CONCRETE PAVEMENT	2,100.00	SY-IN
762000	SAW CUTTING, BITUMINOUS CONCRETE	225.00	L.F.
762001	SAW CUTTING, CONCRETE, FULL DEPTH	21.00	L.F.
811001	FLAGGER, NEW CASTLE COUNTY	178.00	HOUR
811013	FLAGGER, NEW CASTLE COUNTY, OVERTIME	20.00	HOUR
860007	TEMPORARY PAVEMENT STRIPING, LATEX, SYMBOL/LEGEND	950.00	S.F.

DELAWARE DEPARTMENT OF TRANSPORTATION

CONTRACT T202603109

(CAD) PAGE 58 OF 73

CANAL

COMMUNITY TRANSPORTATION FUND, NEW CASTLE IX, 2026

---

LOCATION 19                      **ROBSCOTT MANOR - JANICE DRIVE FROM ALWYN ROAD (INCLUDE INT) TO  
ALDERSHOT DRIVE (INCLUDE INT)**

LENGTH      114.3000 m                                      375.0000 L.F.

**GENERAL IMPROVEMENTS**

2" MILL AND OVERLAY(CURB WHERE NECESSARY)

**COMMENTS:**

INCLUDE BOTH INT. 6 RAMPS @ ALDERSHOT.

---

**MATERIAL ESTIMATE FOR LOCATION 19**

862006	PERMANENT PAVEMENT STRIPING, ALKYD-THERMOPLASTIC, SYMBOL/LEGEND	950.00	S.F.
905004	INLET SEDIMENT CONTROL, DRAINAGE INLET	2.00	EACH
908001	TOPSOIL	30.00	TON
908016	PERMANENT GRASS SEEDING, SUBDIVISION	180.00	S.Y.
908020	EROSION CONTROL BLANKET MULCH	180.00	S.Y.

DELAWARE DEPARTMENT OF TRANSPORTATION

CONTRACT T202603109

(CAD) PAGE 59 OF 73

CANAL

COMMUNITY TRANSPORTATION FUND, NEW CASTLE IX, 2026

---

LOCATION 20 ROSEVILLE PARK - ROSE CIRCLE FROM LAUREL AVENUE CIHM TO CHESTNUT AVENUE CIHM

LENGTH 217.3224 m 713.0000 L.F.

GENERAL IMPROVEMENTS  
2" MILL AND OVERLAY

COMMENTS:

---

MATERIAL ESTIMATE FOR LOCATION 20

202000	EXCAVATION AND EMBANKMENT	3.00	C.Y.
401005	SUPERPAVE TYPE C, 9.5 mm, PG 64-22 (CARBONATE STONE)	250.00	TON
401029	SUPERPAVE TYPE C, 9.5 mm, PG 64-22, PATCHING	1.00	TON
401030	SUPERPAVE TYPE B, PG 64-22, PATCHING	15.00	TON
401506	SPEED HUMP	44.00	L.F.
404001	BITUMINOUS CRACK AND JOINT SEALING LESS THAN 3/4-INCH WIDE	608.00	L.F.
760010	PAVEMENT MILLING, BITUMINOUS CONCRETE PAVEMENT	3,500.00	SY-IN
762000	SAW CUTTING, BITUMINOUS CONCRETE	220.00	L.F.
762001	SAW CUTTING, CONCRETE, FULL DEPTH	80.00	L.F.
811001	FLAGGER, NEW CASTLE COUNTY	117.00	HOUR
811013	FLAGGER, NEW CASTLE COUNTY, OVERTIME	15.00	HOUR

**DELAWARE DEPARTMENT OF TRANSPORTATION**

**CONTRACT T202603109**

**(CAD) PAGE 60 OF 73**

**CANAL**

COMMUNITY TRANSPORTATION FUND, NEW CASTLE IX, 2026

**LOCATION 21 SILVERWOOD - SILVERWOOD BOULEVARD FROM RIDGEWOOD TURN TO VALLEYWOOD CIRCLE (INCLUDE INT)**

LENGTH 449.5800 m 1475.0000 L.F.

**GENERAL IMPROVEMENTS**

2" MILL AND OVERLAY(CURB WHERE NECESSARY)

**COMMENTS:**

INCLUDE INT. @ VALLEYWOOD.

**MATERIAL ESTIMATE FOR LOCATION 21**

202000	EXCAVATION AND EMBANKMENT	20.00	C.Y.
211001	REMOVAL OF PORTLAND CEMENT CONCRETE PAVEMENT, CURB AND SIDEWALK	180.00	S.Y.
301001	GABC	13.00	C.Y.
301002	GABC, PATCHING	30.00	C.Y.
401005	SUPERPAVE TYPE C, 9.5 mm, PG 64-22 (CARBONATE STONE)	480.00	TON
401029	SUPERPAVE TYPE C, 9.5 mm, PG 64-22, PATCHING	101.00	TON
401030	SUPERPAVE TYPE B, PG 64-22, PATCHING	25.00	TON
404001	BITUMINOUS CRACK AND JOINT SEALING LESS THAN 3/4-INCH WIDE	218.00	L.F.
602130	ADJUSTING AND REPAIRING EXISTING DRAINAGE INLET	2.00	EACH
602131	ADJUSTING AND REPAIRING EXISTING DOUBLE DRAINAGE INLET	2.00	EACH
602132	ADJUSTING AND REPAIRING EXISTING MANHOLE	7.00	EACH
701019	I.PCC CURB AND GUTTER, TYPE 2	750.00	L.F.
705002	PCC SIDEWALK, 6"	300.00	S.F.
760010	PAVEMENT MILLING, BITUMINOUS CONCRETE PAVEMENT	7,200.00	SY-IN
762000	SAW CUTTING, BITUMINOUS CONCRETE	750.00	L.F.
762001	SAW CUTTING, CONCRETE, FULL DEPTH	75.00	L.F.
811001	FLAGGER, NEW CASTLE COUNTY	289.00	HOURLY
811013	FLAGGER, NEW CASTLE COUNTY, OVERTIME	30.00	HOURLY
905004	INLET SEDIMENT CONTROL, DRAINAGE INLET	7.00	EACH
908001	TOPSOIL	20.00	TON
908016	PERMANENT GRASS SEEDING, SUBDIVISION	120.00	S.Y.
908020	EROSION CONTROL BLANKET MULCH	120.00	S.Y.

**DELAWARE DEPARTMENT OF TRANSPORTATION**

**CONTRACT T202603109**

**(CAD) PAGE 61 OF 73**

**CANAL**

**COMMUNITY TRANSPORTATION FUND, NEW CASTLE IX, 2026**

**LOCATION 22 SILVERWOOD - VALLEYWOOD CIRCLE FROM SILVERWOOD BOULEVARD TO CUL-DE-SAC.**

LENGTH 50.2920 m 165.0000 L.F.

**GENERAL IMPROVEMENTS**

2" MILL AND OVERLAY(CURB WHERE NECESSARY)

**COMMENTS:**

**MATERIAL ESTIMATE FOR LOCATION 22**

202000	EXCAVATION AND EMBANKMENT	7.00	C.Y.
211001	REMOVAL OF PORTLAND CEMENT CONCRETE PAVEMENT, CURB AND SIDEWALK	18.00	S.Y.
301001	GABC	1.00	C.Y.
301002	GABC, PATCHING	3.00	C.Y.
401005	SUPERPAVE TYPE C, 9.5 mm, PG 64-22 (CARBONATE STONE)	100.00	TON
401029	SUPERPAVE TYPE C, 9.5 mm, PG 64-22, PATCHING	11.00	TON
401030	SUPERPAVE TYPE B, PG 64-22, PATCHING	25.00	TON
404001	BITUMINOUS CRACK AND JOINT SEALING LESS THAN 3/4-INCH WIDE	29.00	L.F.
602131	ADJUSTING AND REPAIRING EXISTING DOUBLE DRAINAGE INLET	1.00	EACH
602132	ADJUSTING AND REPAIRING EXISTING MANHOLE	1.00	EACH
701019	I.PCC CURB AND GUTTER, TYPE 2	90.00	L.F.
705002	PCC SIDEWALK, 6"	30.00	S.F.
760010	PAVEMENT MILLING, BITUMINOUS CONCRETE PAVEMENT	1,700.00	SY-IN
762000	SAW CUTTING, BITUMINOUS CONCRETE	75.00	L.F.
762001	SAW CUTTING, CONCRETE, FULL DEPTH	8.00	L.F.
811001	FLAGGER, NEW CASTLE COUNTY	58.00	HOUR
811013	FLAGGER, NEW CASTLE COUNTY, OVERTIME	8.00	HOUR
905004	INLET SEDIMENT CONTROL, DRAINAGE INLET	3.00	EACH
908001	TOPSOIL	2.00	TON
908016	PERMANENT GRASS SEEDING, SUBDIVISION	12.00	S.Y.
908020	EROSION CONTROL BLANKET MULCH	12.00	S.Y.

DELAWARE DEPARTMENT OF TRANSPORTATION

CONTRACT T202603109

(CAD) PAGE 62 OF 73

CANAL

COMMUNITY TRANSPORTATION FUND, NEW CASTLE IX, 2026

---

**LOCATION 23**                      **SPICE MILL RUN - TARRAGON COURT FROM SPICE MILL LANE TO END**  
LENGTH      131.0640 m                      430.0000 L.F.  
**GENERAL IMPROVEMENTS**  
                    2" MILL AND OVERLAY(CURB WHERE NECESSARY)

**COMMENTS:**

---

**MATERIAL ESTIMATE FOR LOCATION 23**

202000	EXCAVATION AND EMBANKMENT	8.00	C.Y.
211001	REMOVAL OF PORTLAND CEMENT CONCRETE PAVEMENT, CURB AND SIDEWALK	66.00	S.Y.
301001	GABC	6.00	C.Y.
301002	GABC, PATCHING	10.00	C.Y.
401005	SUPERPAVE TYPE C, 9.5 mm, PG 64-22 (CARBONATE STONE)	150.00	TON
401029	SUPERPAVE TYPE C, 9.5 mm, PG 64-22, PATCHING	36.00	TON
401030	SUPERPAVE TYPE B, PG 64-22, PATCHING	10.00	TON
404001	BITUMINOUS CRACK AND JOINT SEALING LESS THAN 3/4-INCH WIDE	50.00	L.F.
602130	ADJUSTING AND REPAIRING EXISTING DRAINAGE INLET	2.00	EACH
701014	PCC CURB, TYPE 2	20.00	L.F.
701023	I.PCC CURB AND GUTTER, TYPE 3-8	200.00	L.F.
705002	PCC SIDEWALK, 6"	102.00	S.F.
760010	PAVEMENT MILLING, BITUMINOUS CONCRETE PAVEMENT	2,200.00	SY-IN
762000	SAW CUTTING, BITUMINOUS CONCRETE	285.00	L.F.
762001	SAW CUTTING, CONCRETE, FULL DEPTH	29.00	L.F.
811001	FLAGGER, NEW CASTLE COUNTY	94.00	HOUR
811013	FLAGGER, NEW CASTLE COUNTY, OVERTIME	11.00	HOUR
905004	INLET SEDIMENT CONTROL, DRAINAGE INLET	3.00	EACH
908001	TOPSOIL	8.00	TON
908016	PERMANENT GRASS SEEDING, SUBDIVISION	46.00	S.Y.
908020	EROSION CONTROL BLANKET MULCH	46.00	S.Y.

**DELAWARE DEPARTMENT OF TRANSPORTATION**

**CONTRACT T202603109**

**(CAD) PAGE 63 OF 73**

**CANAL**

COMMUNITY TRANSPORTATION FUND, NEW CASTLE IX, 2026

**LOCATION 24 STAFFORD II - STAFFORD AVENUE FROM HAWTHORNE AVENUE EAST  
(INCLUDE INT) TO INGLESIDE ROAD**

LENGTH 96.0120 m 315.0000 L.F.

**GENERAL IMPROVEMENTS**

2" MILL AND OVERLAY(CURB WHERE NECESSARY)

**COMMENTS:**

INCLUDE INTERSECTION @ HAWTHORNE AVE. EAST. 2 RAMPS @ HAWTHORNE.

**MATERIAL ESTIMATE FOR LOCATION 24**

202000	EXCAVATION AND EMBANKMENT	4.00	C.Y.
211001	REMOVAL OF PORTLAND CEMENT CONCRETE PAVEMENT, CURB AND SIDEWALK	66.00	S.Y.
301001	GABC	6.00	C.Y.
301002	GABC, PATCHING	4.00	C.Y.
401005	SUPERPAVE TYPE C, 9.5 mm, PG 64-22 (CARBONATE STONE)	150.00	TON
401029	SUPERPAVE TYPE C, 9.5 mm, PG 64-22, PATCHING	13.00	TON
401030	SUPERPAVE TYPE B, PG 64-22, PATCHING	10.00	TON
401506	SPEED HUMP	27.00	L.F.
404001	BITUMINOUS CRACK AND JOINT SEALING LESS THAN 3/4-INCH WIDE	308.00	L.F.
602130	ADJUSTING AND REPAIRING EXISTING DRAINAGE INLET	2.00	EACH
602132	ADJUSTING AND REPAIRING EXISTING MANHOLE	2.00	EACH
701018	I.PCC CURB AND GUTTER, TYPE 1-8	10.00	L.F.
701019	I.PCC CURB AND GUTTER, TYPE 2	50.00	L.F.
705002	PCC SIDEWALK, 6"	36.00	S.F.
705009	PEDESTRIAN CONNECTION, TYPE 2, 3, AND/OR 4	400.00	S.F.
705013	TRUNCATED DOME DETECTABLE WARNING SURFACE	20.00	S.F.
710002	ADJUST WATER VALVE BOXES	1.00	EACH
760010	PAVEMENT MILLING, BITUMINOUS CONCRETE PAVEMENT	2,000.00	SY-IN
762000	SAW CUTTING, BITUMINOUS CONCRETE	190.00	L.F.
762001	SAW CUTTING, CONCRETE, FULL DEPTH	9.00	L.F.
811001	FLAGGER, NEW CASTLE COUNTY	93.00	HOUR
811013	FLAGGER, NEW CASTLE COUNTY, OVERTIME	14.00	HOUR
905004	INLET SEDIMENT CONTROL, DRAINAGE INLET	1.00	EACH
908001	TOPSOIL	3.00	TON
908016	PERMANENT GRASS SEEDING, SUBDIVISION	14.00	S.Y.

DELAWARE DEPARTMENT OF TRANSPORTATION

CONTRACT T202603109

(CAD) PAGE 64 OF 73

CANAL

COMMUNITY TRANSPORTATION FUND, NEW CASTLE IX, 2026

---

LOCATION 24 STAFFORD II - STAFFORD AVENUE FROM HAWTHORNE AVENUE EAST  
(INCLUDE INT) TO INGLESIDE ROAD

LENGTH 96.0120 m 315.0000 L.F.

**GENERAL IMPROVEMENTS**

2" MILL AND OVERLAY(CURB WHERE NECESSARY)

**COMMENTS:**

INCLUDE INTERSECTION @ HAWTHORNE AVE. EAST. 2 RAMPS @ HAWTHORNE.

---

**MATERIAL ESTIMATE FOR LOCATION 24**

908020 EROSION CONTROL BLANKET MULCH

14.00 S.Y.

DELAWARE DEPARTMENT OF TRANSPORTATION

CONTRACT T202603109

(CAD) PAGE 65 OF 73

CANAL

COMMUNITY TRANSPORTATION FUND, NEW CASTLE IX, 2026

---

**LOCATION 25** TUXEDO PARK - WASHINGTON AVE FROM 3 WASHINGTON AVE NEWPORT  
DE 19804 TO 3 WASHINGTON AVE NEWPORT DE 19804

LENGTH 3.6576 m 12.0000 L.F.

**GENERAL IMPROVEMENTS**  
SPEED HUMP

**COMMENTS:**

ONE SPEED HUMP

---

**MATERIAL ESTIMATE FOR LOCATION 25**

401506	SPEED HUMP	22.00	L.F.
404001	BITUMINOUS CRACK AND JOINT SEALING LESS THAN 3/4-INCH WIDE	44.00	L.F.
811001	FLAGGER, NEW CASTLE COUNTY	13.00	HOUR
811013	FLAGGER, NEW CASTLE COUNTY, OVERTIME	1.00	HOUR

DELAWARE DEPARTMENT OF TRANSPORTATION

CONTRACT T202603109

(CAD) PAGE 66 OF 73

CANAL

COMMUNITY TRANSPORTATION FUND, NEW CASTLE IX, 2026

---

LOCATION 26 TUXEDO PARK - WASHINGTON AVE FROM 104 WASHINGTON AVE TO 106  
WASHINGTON AVE

LENGTH  
GENERAL IMPROVEMENTS  
SPEED HUMP

COMMENTS:

ONE SPEED HUMP BETWEEN #104 AND #106

---

MATERIAL ESTIMATE FOR LOCATION 26

401506	SPEED HUMP	22.00	L.F.
404001	BITUMINOUS CRACK AND JOINT SEALING LESS THAN 3/4-INCH WIDE	44.00	L.F.
811001	FLAGGER, NEW CASTLE COUNTY	13.00	HOUR
811013	FLAGGER, NEW CASTLE COUNTY, OVERTIME	1.00	HOUR

**DELAWARE DEPARTMENT OF TRANSPORTATION**

**CONTRACT T202603109**

**(CAD) PAGE 67 OF 73**

**CANAL**

**COMMUNITY TRANSPORTATION FUND, NEW CASTLE IX, 2026**

**LOCATION 27 VALLEY CORPORATE CENTER - BRIDLE PATH FROM CUL-DE-SAC TO S. RIDING BOULEVARD**

LENGTH 109.7280 m 360.0000 L.F.

**GENERAL IMPROVEMENTS**

2" MILL AND OVERLAY(CURB WHERE NECESSARY)

**COMMENTS:**

3 RAMPS @ STIRRUP. 2 RAMPS @ S. RIDING.

**MATERIAL ESTIMATE FOR LOCATION 27**

202000	EXCAVATION AND EMBANKMENT	5.00	C.Y.
211001	REMOVAL OF PORTLAND CEMENT CONCRETE PAVEMENT, CURB AND SIDEWALK	150.00	S.Y.
301001	GABC	15.00	C.Y.
301002	GABC, PATCHING	6.00	C.Y.
401005	SUPERPAVE TYPE C, 9.5 mm, PG 64-22 (CARBONATE STONE)	150.00	TON
401029	SUPERPAVE TYPE C, 9.5 mm, PG 64-22, PATCHING	18.00	TON
401030	SUPERPAVE TYPE B, PG 64-22, PATCHING	10.00	TON
404001	BITUMINOUS CRACK AND JOINT SEALING LESS THAN 3/4-INCH WIDE	108.00	L.F.
701013	PCC CURB, TYPE 1-8	8.00	L.F.
701019	I.PCC CURB AND GUTTER, TYPE 2	80.00	L.F.
705001	PCC SIDEWALK, 4"	250.00	S.F.
705002	PCC SIDEWALK, 6"	48.00	S.F.
705008	PEDESTRIAN CONNECTION, TYPE 1	100.00	S.F.
705009	PEDESTRIAN CONNECTION, TYPE 2, 3, AND/OR 4	1,000.00	S.F.
705013	TRUNCATED DOME DETECTABLE WARNING SURFACE	50.00	S.F.
710002	ADJUST WATER VALVE BOXES	1.00	EACH
760010	PAVEMENT MILLING, BITUMINOUS CONCRETE PAVEMENT	1,420.00	SY-IN
760011	PAVEMENT MILLING, BITUMINOUS CONCRETE PAVEMENT, TAPER CUT	370.00	SY-IN
762000	SAW CUTTING, BITUMINOUS CONCRETE	170.00	L.F.
762001	SAW CUTTING, CONCRETE, FULL DEPTH	12.00	L.F.
811001	FLAGGER, NEW CASTLE COUNTY	102.00	HOUR
811013	FLAGGER, NEW CASTLE COUNTY, OVERTIME	13.00	HOUR
905004	INLET SEDIMENT CONTROL, DRAINAGE INLET	1.00	EACH
908001	TOPSOIL	23.00	TON
908016	PERMANENT GRASS SEEDING, SUBDIVISION	139.00	S.Y.

DELAWARE DEPARTMENT OF TRANSPORTATION

CONTRACT T202603109

(CAD) PAGE 68 OF 73

CANAL

COMMUNITY TRANSPORTATION FUND, NEW CASTLE IX, 2026

---

LOCATION 27 VALLEY CORPORATE CENTER - BRIDLE PATH FROM CUL-DE-SAC TO S.  
RIDING BOULEVARD

LENGTH 109.7280 m 360.0000 L.F.

GENERAL IMPROVEMENTS

2" MILL AND OVERLAY(CURB WHERE NECESSARY)

COMMENTS:

3 RAMPS @ STIRRUP. 2 RAMPS @ S. RIDING.

---

MATERIAL ESTIMATE FOR LOCATION 27

908020 EROSION CONTROL BLANKET MULCH

139.00 S.Y.

**DELAWARE DEPARTMENT OF TRANSPORTATION**

**CONTRACT T202603109**

**(CAD) PAGE 69 OF 73**

**CANAL**

**COMMUNITY TRANSPORTATION FUND, NEW CASTLE IX, 2026**

**LOCATION 28 VIDERE WOODS - VIDERE DRIVE FROM HOUSE #2957 CIHM TO CONSPECTUS DRIVE (SOUTH INT-INCLUDE INT)**

LENGTH 192.3288 m 631.0000 L.F.

**GENERAL IMPROVEMENTS**

2" MILL AND OVERLAY(CURB WHERE NECESSARY)

**COMMENTS:**

INCLUDE INT. CONSPECTUS DR., 4 ADA RAMPS @ CONSPECTUS DR., 2 ADA RAMPS @ HOUSE 2957.

**MATERIAL ESTIMATE FOR LOCATION 28**

202000	EXCAVATION AND EMBANKMENT	8.00	C.Y.
211001	REMOVAL OF PORTLAND CEMENT CONCRETE PAVEMENT, CURB AND SIDEWALK	200.00	S.Y.
301001	GABC	16.00	C.Y.
301002	GABC, PATCHING	9.00	C.Y.
401005	SUPERPAVE TYPE C, 9.5 mm, PG 64-22 (CARBONATE STONE)	225.00	TON
401029	SUPERPAVE TYPE C, 9.5 mm, PG 64-22, PATCHING	32.00	TON
401030	SUPERPAVE TYPE B, PG 64-22, PATCHING	15.00	TON
404001	BITUMINOUS CRACK AND JOINT SEALING LESS THAN 3/4-INCH WIDE	221.00	L.F.
602130	ADJUSTING AND REPAIRING EXISTING DRAINAGE INLET	1.00	EACH
602132	ADJUSTING AND REPAIRING EXISTING MANHOLE	3.00	EACH
701013	PCC CURB, TYPE 1-8	9.00	L.F.
701019	I.PCC CURB AND GUTTER, TYPE 2	50.00	L.F.
701023	I.PCC CURB AND GUTTER, TYPE 3-8	100.00	L.F.
705001	PCC SIDEWALK, 4"	300.00	S.F.
705002	PCC SIDEWALK, 6"	90.00	S.F.
705008	PEDESTRIAN CONNECTION, TYPE 1	120.00	S.F.
705009	PEDESTRIAN CONNECTION, TYPE 2, 3, AND/OR 4	1,200.00	S.F.
705013	TRUNCATED DOME DETECTABLE WARNING SURFACE	60.00	S.F.
710002	ADJUST WATER VALVE BOXES	2.00	EACH
760010	PAVEMENT MILLING, BITUMINOUS CONCRETE PAVEMENT	3,370.00	SY-IN
762000	SAW CUTTING, BITUMINOUS CONCRETE	292.00	L.F.
762001	SAW CUTTING, CONCRETE, FULL DEPTH	22.00	L.F.
811001	FLAGGER, NEW CASTLE COUNTY	172.00	HOUR
811013	FLAGGER, NEW CASTLE COUNTY, OVERTIME	21.00	HOUR
905004	INLET SEDIMENT CONTROL, DRAINAGE INLET	2.00	EACH

DELAWARE DEPARTMENT OF TRANSPORTATION

CONTRACT T202603109

(CAD) PAGE 70 OF 73

CANAL

COMMUNITY TRANSPORTATION FUND, NEW CASTLE IX, 2026

---

LOCATION 28 VIDERE WOODS - VIDERE DRIVE FROM HOUSE #2957 CIHM TO CONSPECTUS DRIVE (SOUTH INT-INCLUDE INT)

LENGTH 192.3288 m 631.0000 L.F.

**GENERAL IMPROVEMENTS**

2" MILL AND OVERLAY(CURB WHERE NECESSARY)

**COMMENTS:**

INCLUDE INT. CONSPECTUS DR., 4 ADA RAMPS @ CONSPECTUS DR., 2 ADA RAMPS @ HOUSE 2957.

---

**MATERIAL ESTIMATE FOR LOCATION 28**

908001	TOPSOIL	30.00	TON
908016	PERMANENT GRASS SEEDING, SUBDIVISION	180.00	S.Y.
908020	EROSION CONTROL BLANKET MULCH	180.00	S.Y.

DELAWARE DEPARTMENT OF TRANSPORTATION

CONTRACT T202603109

(CAD) PAGE 71 OF 73

CANAL

COMMUNITY TRANSPORTATION FUND, NEW CASTLE IX, 2026

---

**LOCATION 29**                      **BROOKLAND TERRACE - BEECH AVENUE FROM CENTRE ROAD ROUTE  
SR141 (JOINT NEAR INLETS) TO DEAD END**

LENGTH      106.6800 m                      350.0000 L.F.

**GENERAL IMPROVEMENTS**

2" MILL AND OVERLAY(CURB WHERE NECESSARY)

**COMMENTS:**

---

**MATERIAL ESTIMATE FOR LOCATION 29**

401005	SUPERPAVE TYPE C, 9.5 mm, PG 64-22 (CARBONATE STONE)	100.00	TON
401029	SUPERPAVE TYPE C, 9.5 mm, PG 64-22, PATCHING	1.00	TON
401030	SUPERPAVE TYPE B, PG 64-22, PATCHING	13.00	TON
404001	BITUMINOUS CRACK AND JOINT SEALING LESS THAN 3/4-INCH WIDE	275.00	L.F.
602132	ADJUSTING AND REPAIRING EXISTING MANHOLE	1.00	EACH
760010	PAVEMENT MILLING, BITUMINOUS CONCRETE PAVEMENT	1,400.00	SY-IN
762000	SAW CUTTING, BITUMINOUS CONCRETE	275.00	L.F.
802003	ARROW PANELS TYPE C	2.00	EA-DY
808002	PROVIDE AND MAINTAIN TRUCK MOUNTED ATTENUATOR, TYPE II	2.00	EA-DY
811001	FLAGGER, NEW CASTLE COUNTY	39.00	HOUR
811013	FLAGGER, NEW CASTLE COUNTY, OVERTIME	6.00	HOUR

---

**DELAWARE DEPARTMENT OF TRANSPORTATION****CONTRACT T202603109****(CAD) PAGE 72 OF 73****CANAL****COMMUNITY TRANSPORTATION FUND, NEW CASTLE IX, 2026**

---

**CONTRACT QUANTITIES SUMMARY SHEET**

202000	EXCAVATION AND EMBANKMENT	283.00	C.Y.
211001	REMOVAL OF PORTLAND CEMENT CONCRETE PAVEMENT, CURB AND SIDEWALK	2,078.00	S.Y.
301001	GABC	209.00	C.Y.
301002	GABC, PATCHING	176.00	C.Y.
401005	SUPERPAVE TYPE C, 9.5 mm, PG 64-22 (CARBONATE STONE)	3,530.00	TON
401029	SUPERPAVE TYPE C, 9.5 mm, PG 64-22, PATCHING	564.00	TON
401030	SUPERPAVE TYPE B, PG 64-22, PATCHING	341.00	TON
401506	SPEED HUMP	257.00	L.F.
404001	BITUMINOUS CRACK AND JOINT SEALING LESS THAN 3/4-INCH WIDE	4,381.00	L.F.
602100	DRAINAGE INLET GRATE(S)	1.00	EACH
602101	DRAINAGE INLET FRAME(S)	1.00	EACH
602102	MANHOLE COVER(S)	2.00	EACH
602103	MANHOLE FRAME(S)	2.00	EACH
602130	ADJUSTING AND REPAIRING EXISTING DRAINAGE INLET	19.00	EACH
602131	ADJUSTING AND REPAIRING EXISTING DOUBLE DRAINAGE INLET	3.00	EACH
602132	ADJUSTING AND REPAIRING EXISTING MANHOLE	26.00	EACH
701013	PCC CURB, TYPE 1-8	135.00	L.F.
701014	PCC CURB, TYPE 2	20.00	L.F.
701018	I.PCC CURB AND GUTTER, TYPE 1-8	90.00	L.F.
701019	I.PCC CURB AND GUTTER, TYPE 2	2,590.00	L.F.
701023	I.PCC CURB AND GUTTER, TYPE 3-8	320.00	L.F.
705001	PCC SIDEWALK, 4"	1,844.00	S.F.
705002	PCC SIDEWALK, 6"	3,158.00	S.F.
705008	PEDESTRIAN CONNECTION, TYPE 1	760.00	S.F.
705009	PEDESTRIAN CONNECTION, TYPE 2, 3, AND/OR 4	9,400.00	S.F.
705013	TRUNCATED DOME DETECTABLE WARNING SURFACE	470.00	S.F.
710002	ADJUST WATER VALVE BOXES	8.00	EACH
710370	STEEL CASING PIPE, 4"	70.00	L.F.

---

DELAWARE DEPARTMENT OF TRANSPORTATION

CONTRACT T202603109

(CAD) PAGE 73 OF 73

CANAL

COMMUNITY TRANSPORTATION FUND, NEW CASTLE IX, 2026

---

CONTRACT QUANTITIES SUMMARY SHEET

760010	PAVEMENT MILLING, BITUMINOUS CONCRETE PAVEMENT	49,930.00	SY-IN
760011	PAVEMENT MILLING, BITUMINOUS CONCRETE PAVEMENT, TAPER CUT	1,350.00	SY-IN
762000	SAW CUTTING, BITUMINOUS CONCRETE	5,396.00	L.F.
762001	SAW CUTTING, CONCRETE, FULL DEPTH	948.00	L.F.
763000	INITIAL EXPENSE/DE-MOBILIZATION	LUMP	SUM
801500	MAINTENANCE OF TRAFFIC, REHABILITATION	LUMP	SUM
802003	ARROW PANELS TYPE C	8.00	EA-DY
803001	PROVIDE AND MAINTAIN PORTABLE CHANGEABLE MESSAGE SIGN	24.00	EA-DY
808002	PROVIDE AND MAINTAIN TRUCK MOUNTED ATTENUATOR, TYPE II	12.00	EA-DY
811001	FLAGGER, NEW CASTLE COUNTY	2,694.00	HOUR
811013	FLAGGER, NEW CASTLE COUNTY, OVERTIME	318.00	HOUR
819003	INSTALL OR REMOVE TRAFFIC SIGNS	5.00	EACH
860004	TEMPORARY MARKINGS, LATEX, 4"	330.00	L.F.
860007	TEMPORARY PAVEMENT STRIPING, LATEX, SYMBOL/LEGEND	1,630.00	S.F.
861001	PERMANENT PAVEMENT STRIPING, EPOXY RESIN PAINT, 6"	330.00	L.F.
862006	PERMANENT PAVEMENT STRIPING, ALKYD-THERMOPLASTIC, SYMBOL/LEGEND	1,630.00	S.F.
905004	INLET SEDIMENT CONTROL, DRAINAGE INLET	28.00	EACH
908001	TOPSOIL	264.00	TON
908016	PERMANENT GRASS SEEDING, SUBDIVISION	1,578.00	S.Y.
908020	EROSION CONTROL BLANKET MULCH	1,578.00	S.Y.